

Mud Sucker®  
Diaphragm Pumps

# 23FA-EC Series

Heavy Duty  
Diaphragm Pumps

23FA-EC™

23FA-EC-C™

## FEATURES

2" Connection size

Pump up to 50 GPM

Transfer spherical solids up to  
1½" or 50% by volume

Suction capabilities up to 100'

Heavy duty diaphragm

Multiple drive options and  
industry specific components

  
**WASTECORP**  
Pumps®



## Up to 50 GPM Pumping Capabilities. The Ultimate Heavy Duty Diaphragm Pump

If you're pumping wastewater, slurry, waste oil, septic waste or food processing renderings, then you need to take a close look at the Mud Sucker 23FA Series designed and manufactured by Wastecorp Pumps. This is a heavy duty flapper valve style diaphragm pump that can run dry and transfer up to 50 GPM with up to 100' of suction\*

### Make Pumping Tough Fluids Easier



#### EXCLUSIVE CONTOURED VELOCITY CHANNEL

Only with Mud Sucker pumps do you get an industry exclusive velocity channel that enhance the flow of fluids and reduces the chance for clogging

#### MULTIPLE APPLICATIONS

With standard Santoprene diaphragms you can tackle tough pumping jobs like general wastewater, solids and industrial fluids

#### CONFIGURED FOR YOUR FACILITY

With custom mounting systems available and your choice of in-line or standard piping systems, you get a pump designed for your facility.

### WHAT THIS MEANS TO YOU.

The pump adapts to your unique fluid handling environment. Experience increased productivity and less downtime.

Higher quality materials help you extend the life of your investment for high demand applications.

Get solutions for tight spaces, piping arrangements and industry specific components that you need to get the job done right the first time.

**MUD SUCKER® DIAPHRAGM PUMPS THE PUMP WITH ATTITUDE.**

**wastecorp.com**

\*Figures based on pumping water. Flow rate may be affected by percentage of solids, thickness of fluid, elevation and other factors. Let your Wastecorp representative know what you are pumping and how far you need to discharge the fluid before ordering.

## Mud Sucker® Diaphragm Pumps

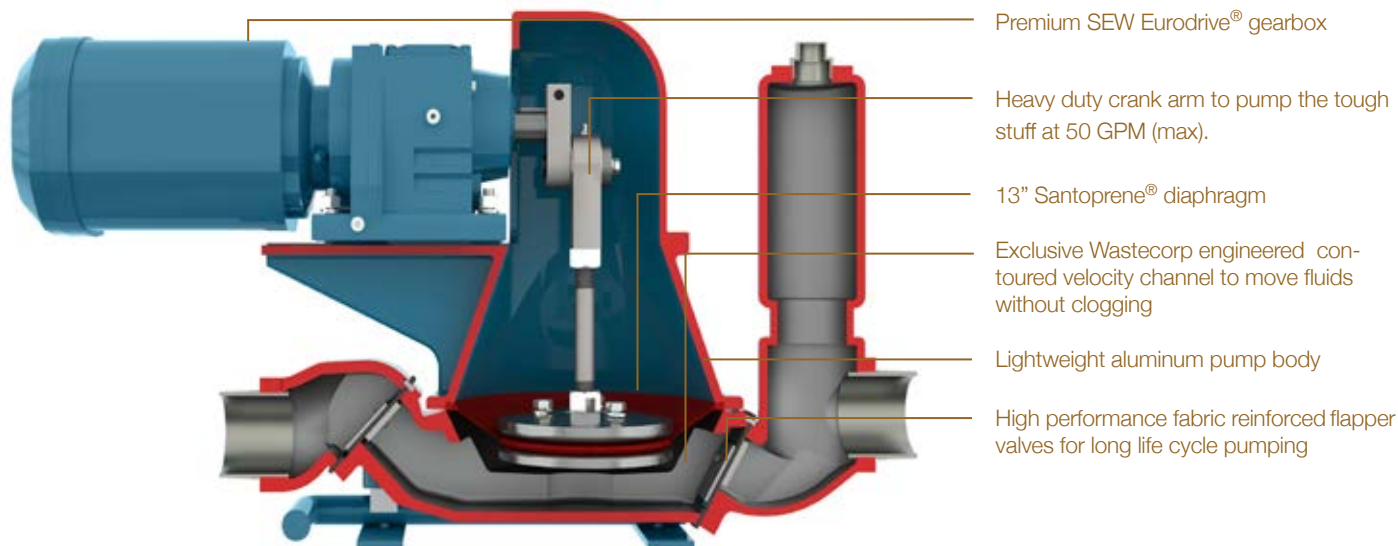

Mud Sucker 23FA Series is manufactured in North America (USA/Canada).

### Performance Range

Max. capacity	50 GPM
Max. suction distance	100' horizontal or 20 ft vertical
Max. discharge head	20 psi
Solids handling	1½" dia or 50% by volume

### Pump Specifications

Suction inlet/outlet size	2"x2" (female threaded)
Max. liquid temperature	220°F (104°C) continuous*
Pump body casing	Aluminum A356, heat treated
Diaphragm	13" OD TPE Santoprene® severe duty
Flapper valves	HNBR w/ reinforced tire cord
Gear reducer	SEW Eurodrive/Siemens
Crankarm	AISI 1045 HR steel
Pump rod	AISI 12L14 carbon steel
Pump operating speed	60 RPM

### Motor Options

Description	Part No.	Motor Option
Standard motor (TEFC)	65156-10	2 hp, 1800RPM/3/60/230-460V TEFC
Single Phase (TEFC)	65156-00	2 hp, 1800RPM/1/60/115-230V TEFC
Wheel Mount Kit	61316-00	

### Popular 23FA Series Applications

- Pacified Chemical Sludge
- Lime Slurry
- Waste Oil Sludge
- Fiberboard Filler
- Raw Latex
- Clay Slurries
- Cruise Ship Wastes
- Food Processing Waste (pork, cattle, fish, fruit, vegetable, dairy, poultry)
- Paper Pump Transfer
- Explosive Jelly
- Paint Transfer
- Polymer Transfer
- Ship Bilge Transfer
- Metal Slurry Transfer
- Holding Tank Transfer
- Coal Slurry
- Hog Fat
- Chemical Filler Materials
- Chocolate Waste Product Transfer
- Portable Trash/Clean-up
- Sludge Recovery (tanker mounted units)
- Ferric Chloride
- Mobile Dewatering
- Feed Pump
- Lagoon Cleaning
- Golf Courses
- Harbor Pumps
- Federal/Military
- Railroad Tanker Cleaning
- Thickened Sludge Transfer
- Scum Feed Pumps
- Portable Clean-up Pump Sets
- Centrifuge Feed Pumps
- Lime Slurry Transfer
- Lagoon Dredging
- Septic Transfer
- State/Federal Parks & Recreation
- Emergency Management Response

\* Consult factory if fluid temperature exceeds 140°F



**WASTECORP**  
**Pumps®**

**OEM Manufacturer**

## Mud Sucker® Diaphragm Pumps

Toll-Free: 1.888.829.2783 Email: [info@wastecorp.com](mailto:info@wastecorp.com)

Mud Sucker 23FA Series pumps are specified for the following industries and applications: wastewater, septic waste oil pumping, agricultural, aquaculture farming, farms, food processing, oil, gas, shale, select chemicals, pulp and paper mills, marine pumping applications, landfills, dewatering, biodiesel production and others. Mention your application to your technical support representative at the time of order. Before operating your diaphragm pump, read, understand and follow all instructions in the manual and on the pump. Specifications and programs are accurate at the time of publication but subject to change without notice. Images may not reflect dealer inventory and/or unit specifications. Wastecorp, Mud Sucker and globes are trademarks of Wastecorp Pumps Inc. No reproduction of this document without permission. © Wastecorp 2023 V2.

## Mud Sucker 23FA Series Performance Curve



Wheel kit available.

## Mud Sucker 23FA Series Dimensional Drawing

The discharge pulsation dampener is designed to control pressure surge waves called hydraulic transient. Also known as water hammer, pulsation dampeners will reduce these surges by up to 90%. Pulsation dampener is recommended.

**With Discharge Air Chamber  
(Recommended)**

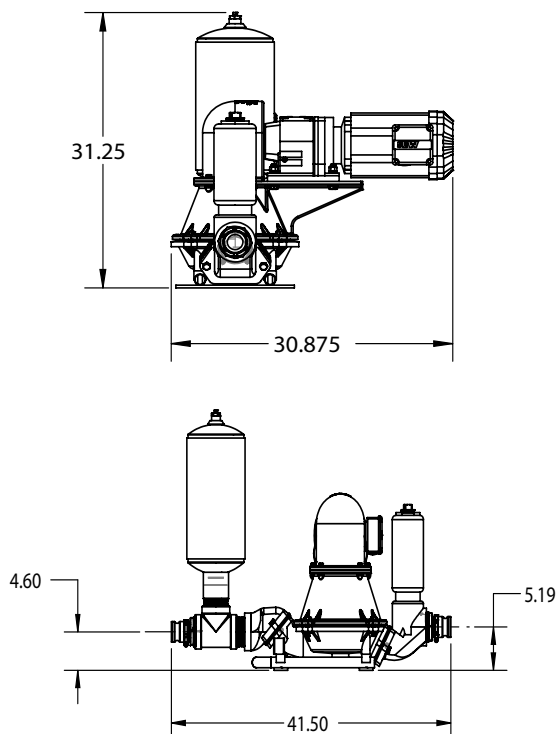

**Standard Design**

