

**Mud Sucker®
Diaphragm Pumps
3FA-EC Series**

**Heavy Duty
Diaphragm Pumps**

FEATURES

3" Connection size

Pump up to 70 GPM

Transfer spherical solids up to
2.25" or 50% by volume

13" heavy duty diaphragm



**ENERGY EFFICIENT ELECTRIC DIAPHRAGM
PUMPS THAT GET THE JOB DONE.**

The Mud Sucker® 3FA Series is a heavy duty 3" diaphragm pump that is designed to transfer wastewater, slurry and solids for multiple applications and industries. We developed the exclusive **Contoured Velocity Channel** which aids in moving tough fluids through the pump body and enhancing overall performance. We worked with leading chemical companies to offer high wear components like Santoprene® diaphragms and fabric reinforced flapper valves. This helps to move tough fluids while reducing downtime for maintenance. With every innovation, we move diaphragm pump technology forward because our customers demand it.

Make Pumping Tough Fluids Easier

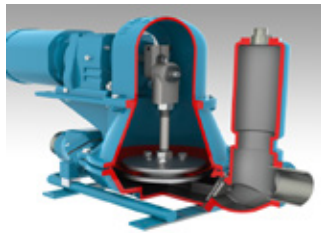

**EXCLUSIVE CONTOURED
VELOCITY CHANNEL**

Only with Mud Sucker pumps do you get an industry exclusive velocity channel that enhance the flow of fluids and reduces the chance for clogging

MOBILITY OPTIONS

Moving your Mud Sucker around your facility is easy with Wastecorp's mobility options including dolly's, trailers and carts all custom designed for your needs.

**CONFIGURED FOR YOUR
FACILITY**

With custom mounting systems available and your choice of in-line or standard piping systems, you get a pump designed for your facility.

WHAT THIS MEANS TO YOU.

The pump adapts to your unique fluid handling environment. Experience increased productivity and less downtime.

Move your pump with ease around job sites and get the mobility package you need

Get solutions for tight spaces, piping arrangements and industry specific components that you need to get the job done right the first time.

**Mud Sucker®
Diaphragm Pumps
3FA-EC Series**

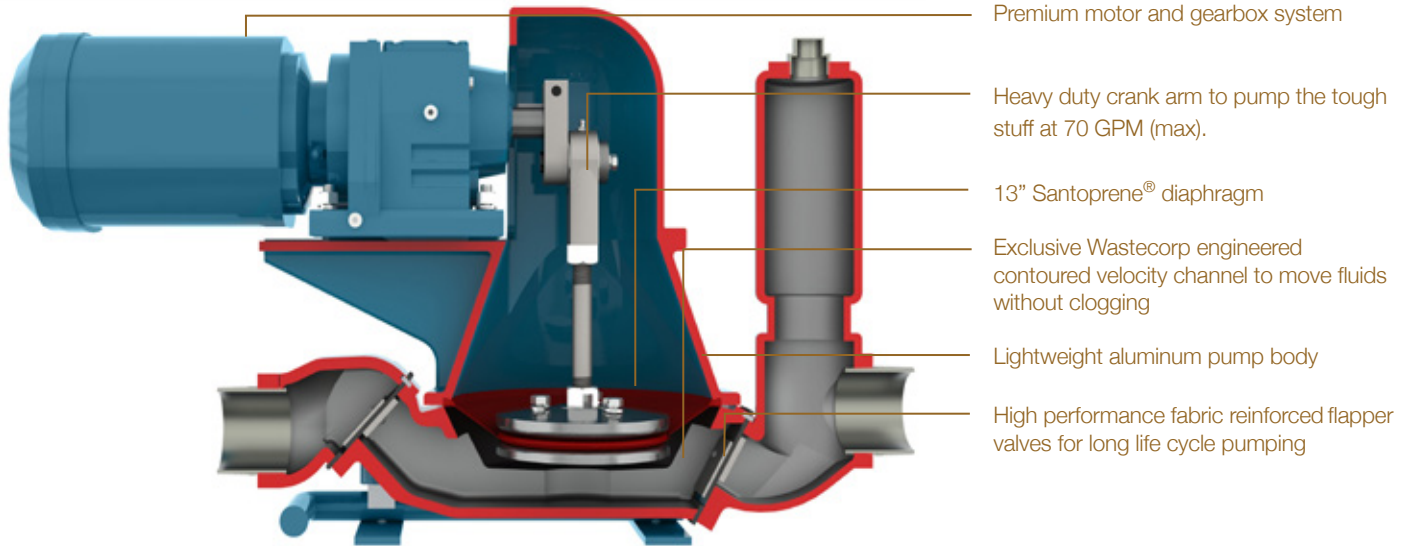

- Premium motor and gearbox system
- Heavy duty crank arm to pump the tough stuff at 70 GPM (max).
- 13" Santoprene® diaphragm
- Exclusive Wastecorp engineered contoured velocity channel to move fluids without clogging
- Lightweight aluminum pump body
- High performance fabric reinforced flapper valves for long life cycle pumping

Mud Sucker 3FA Series is manufactured in North America (USA/Canada)

Performance Range

Max. capacity	70 GPM
Max. suction lift	25' vertical
Max. discharge head	50' vertical
Solids handling	2.25" dia or 50% by volume

Pump Specifications

Suction inlet/outlet size	3"x3" (female threaded)
Max. liquid temperature	140°F (60°C) continuous*
Pump body casing	Aluminum
Diaphragm	13" dia TPE Santoprene® Severe duty
Flapper valves	Fabric reinforced Buna-N (viton optional)
Gearbox	SEW Eurodrive
RPM Speed	53
Rod end bearing body	Cast iron, protective coated for corrosion resistance

Motor Options

Description	Part No.	Model Option
MUD SUCKER 3FA-EC DIAPHRAGM PUMP, single phase electric	66596-15	2 hp/1ph/60Hz/110-220v
MUD SUCKER 3FA-EC DIAPHRAGM PUMP, Three phase	66596-10	2 hp/3ph/60Hz/230-460v

Popular 3FA Series Applications

- Pacified Chemical Sludge
- Lime Slurry
- Waste Oil Sludge
- Fiberboard Filler
- Raw Latex
- Clay Slurries
- Cruise Ship Wastes
- Food Processing Waste (pork, cattle, fish, fruit, vegetable, dairy, poultry)
- Paper Pump Transfer
- Explosive Jelly
- Paint Transfer
- Polymer Transfer
- Ship Bilge Transfer
- Metal Slurry Transfer
- Holding Tank Transfer
- Coal Slurry
- Hog Fat
- Chemical Filler Materials
- Chocolate Waste Product Transfer
- Portable Trash/Clean-up
- Sludge Recovery (tanker mounted units)
- Ferric Chloride
- Mobile Dewatering
- Feed Pump
- Lagoon Cleaning
- Harbor Pumps
- Federal/Military Railroad Tanker Cleaning
- Thickened Sludge Transfer
- Scum Feed Pumps
- Portable Clean-up Pump Sets
- Centrifuge Feed Pumps
- Lime Slurry Transfer
- Lagoon Dredging
- Septic Transfer
- State/Federal Parks & Recreation
- Emergency Management Response

* Consult factory if fluid temperature exceeds 140 °F

Mud Sucker®
Diaphragm Pumps
3FA-EC Series



Mud Sucker 3FA Series General Dimensions

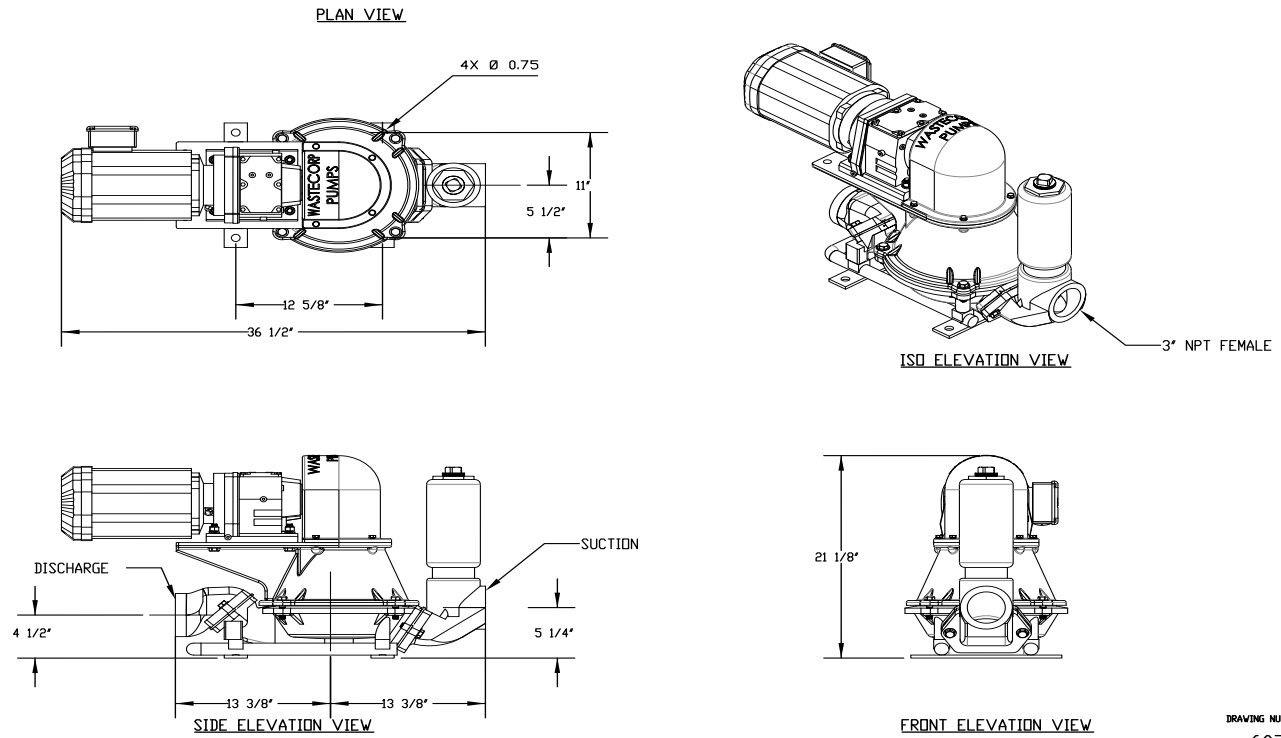

**Mud Sucker 3FA Series With Air Chambers (Pulsation Control)
General Dimensions**

Positive displacement pumps by nature, generate a pulsating flow. When the ball / flapper valves open and close, the momentum of the liquid reacts in the form of water hammer which is absorbed by the hose or pipe. By installing a pulsation dampener, it will act as surge suppressor and reduce turbulence in the pipe. The increased volumetric expansion and absorption of the fluid results in a substantial reduction of water hammer and motor amp draw fluctuations.

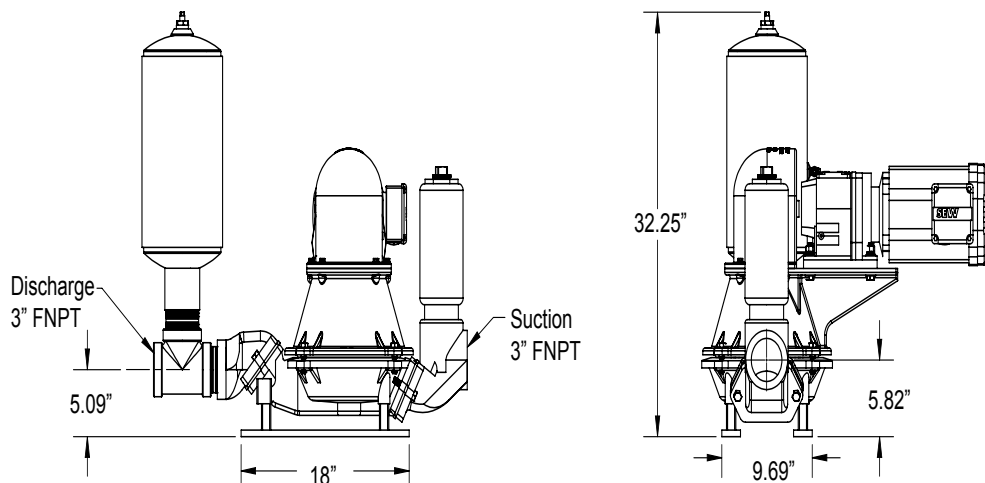

Mud Sucker®
Diaphragm Pumps
3FA-EC Series

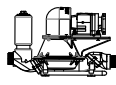
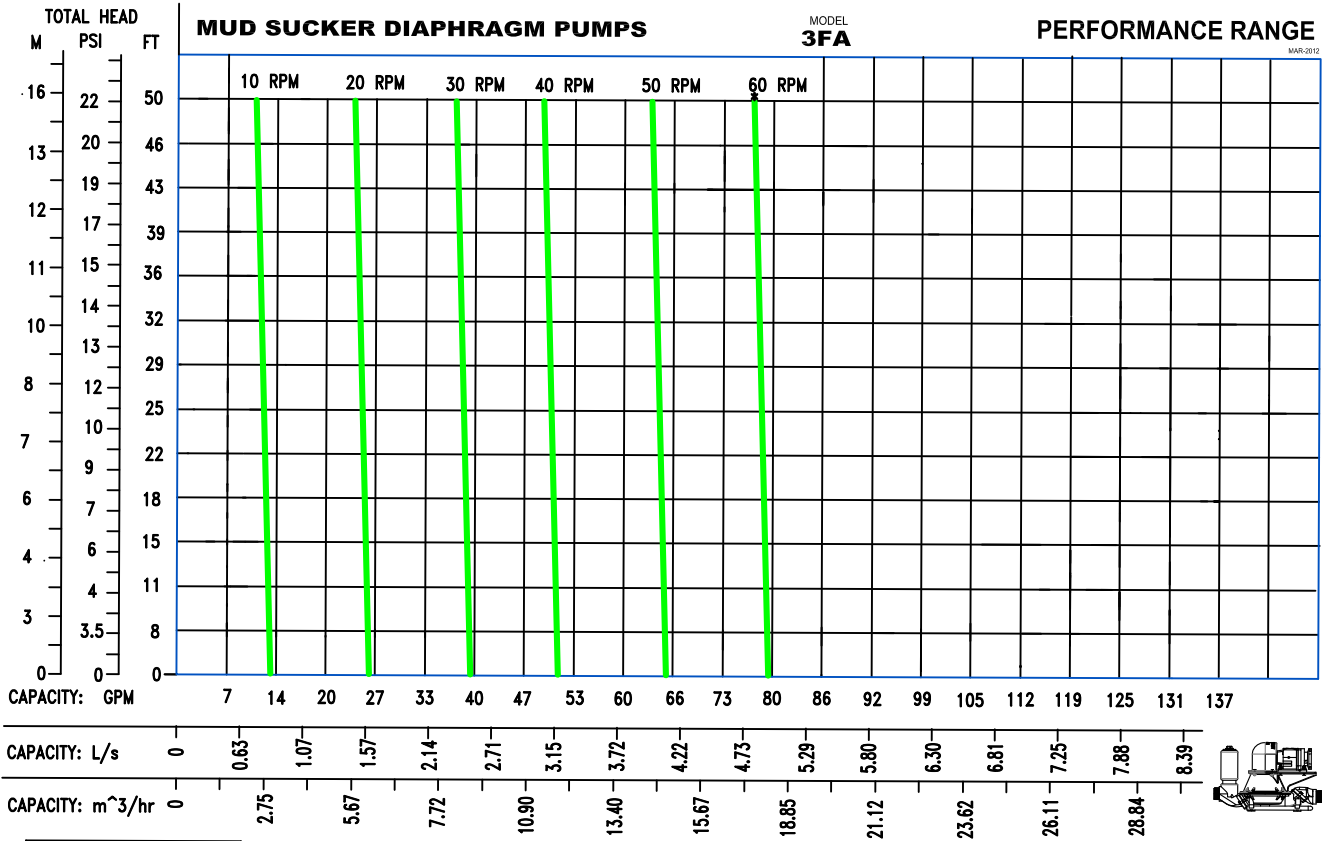

REPRIMING LIFTS

THIS PUMP IS CAPABLE OF VERTICAL SUCTIONS LIFTS UP TO 25FT (7.6M) OR 75FT (23M) HORIZONTAL AT SEA LEVEL DEPENDING ON PIPE CONFIGURATION. THE HORIZONTAL SUCTION LENGTH CAN BE INCREASED BY INSTALLING CHECK VALVES INLINE TO ASSIST DURING LONGER SUCTION RUNS.

NPSHr / EFFECENCY %

THE LOW OVERALL SPEED OF THIS POSITIVE DISPLACEMENT PUMP PERMITS TRANSFER OF AIR AND LIQUID WITH MINIMAL RISK OF CAVITATION AND LOW NPSHr REQUIREMENTS. FURTHER BENEFITS OF THIS PUMP DESIGN IS THAT IT IS LOW SHEARING AND HAS VOLUMETRIC EFFECENCY EXCEEDING 90%

* NORMAL AVERAGE RPM SPEED SET FROM FACTORY



www.wastecorp.com











CURVE NO.: 62934-00 MODEL: 3FA
SIZE: 3" x 3" DIAPHRAGM DIA: 13"
RPM: VARIOUS SP. GR.: 1.0 @ 68°F

DISPLACEMENT PER ONE REVOLUTION OF OUTPUT SHAFT: 1.3 Gal. [4.92 L]

Factory certified tests are performed using Hydraulic Institute acceptance Level B. The performance curve shown were taken from actual tests of standard production pumps, and reflect an average performance of the pumps indicated. Wastecorp reserves the right to make changes in design, materials and operating ranges without notice.

ACCESSORIES

Enhanced pump out productivity with your Mud Sucker diaphragm pump can be as easy as adding a few simple accessories. So if you need to suck up dirt and debris, need a mess-free pump out, or have a heavier duty dewatering application, the right accessories can enhance your fluid handling one step further.

	Part no.	Description		Part no.	Description
	61287-00 61287-10	Basic spare parts kit (diaphragm and flappers). Santoprene (red) P/N: 61287-00. Neoprene black P/N: 61287-10		61286-00 61286-10	Comprehensive spare parts kit (diaphragm, flappers gaskets, weights and hardware) Santoprene (red) P/N: 61286-00. Neoprene (black) P/N: 61286-10
	60466-00	Camlock fitting 3" alum. (Part A) male adapter x female NPT		61316-00	Wheel mount kit with handles (In-line)
	34383-00	Stainer, square hole (solids) 3" FNPT		60581-00	Strainer (Non-clog) round hole
	69999-99	Mobility package (stationary) lifting bars		61292-00	Professional Wagon kit, 16" pneumatic tires
	61605-00	Air chamber (discharge side). Pulsation dampening		51054-00	Non-collapsible EPDM hose 3"x20'. Camlocks included. Longer lengths available
	51314-10	Discharge hose, lay flat (brown) 3"x10'. Camlocks included. Longer lengths available			