

SUPER DUTY® VACUUM PUMPS

**TVP-300™ Series**  
Slide-In

CALL 1-888-829-2783

  
**WASTECORP**  
Pumps®



**STRONG PUMPING POWER. UNBEATABLE QUALITY.  
YOUR NEED A SUPER DUTY.**

## FEATURES

- 300 US gallon heavy duty steel tank
- Built-in forklift pockets
- Mounting options available for trucks, platforms.
- Several vacuum pump options available
- Heavy duty steel tank with sight eyes and manway options
- Fast tank emptying with reverse flow available
- Premium hoses available in a variety of lengths

## THE SUPER DUTY IS MADE FOR

- Septic waste pumping
- Portable toilet servicing
- General wastewater cleanup
- Clean out car wash sediment pits
- Storm drain, catch basin pumping and cleaning
- Septic tank pumping

## TVP-300 Slide-In Specifications

Model	TVP-300-SL(127)	TVP-300-SL(230)
Vacuum/Pressure	127CFM	230 CFM
Typical applications	Grease Trap & Portable Toilets	Septic Tank / Sump Pits /
Part Number	64954-00	64954-70
Tank		
Capacity	300 US Gallons	
Base Frame	Heavy Duty Fabricated Steel	
Tank Material	A36 Carbon Steel	
Sight Eyes	(2) 5" Glass	
Manway	12" Primary Top Door	
Hose Rack	(2) Hooks on rear or side of tank	
Engine		
Gas Engine	9 hp Honda/Kohler Gas E-Start	14 hp Honda/Kohler Gas E-Start
Optional Engine	10 hp Hatz Diesel E-Start	17 hp Kohler Diesel E-Start
Power Transmission	Belt Driven	
Hoses		
Suction Hose	30 ft Non-Collapsible with Alum. Camlock Fittings (longer lengths available)	
Discharge Hose	10 ft Layflat with Alum. Camlock Fittings (longer lengths available)	
Port Sizes		
	2" Valve with Camlock	3" Lever Valve with Camlock
Off-Load Port Size	3" Lever Valve with Camlock	4" Lever Valve with Camlock
Suction Vac Wand:	5 ft PVC Pipe with 90° Camlock	
Overall (Approximate)		
Dry Weight (lb):	1250-1500 lbs	
Loaded (water)	2400-2650 lbs	

DESIGNED AND MANUFACTURED BY WASTECORP PUMPS IN NORTH AMERICA.

## TVP-300 Slide-In Dimensions

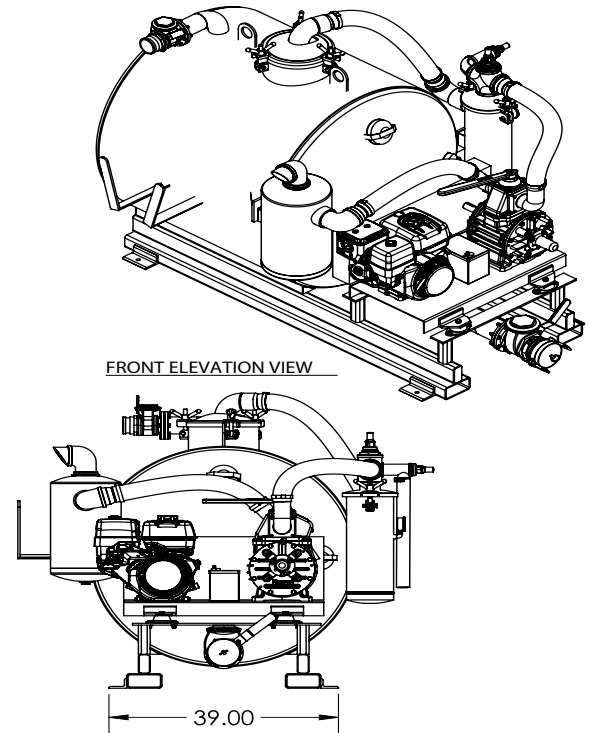
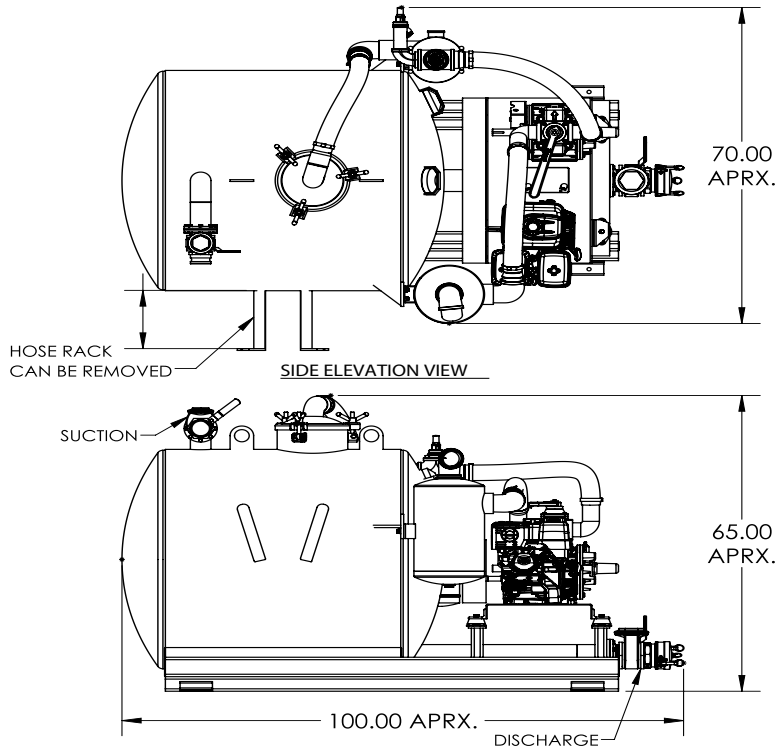

Mount in ATV (Select models only)



Mount on land, concrete or docks



Slide-in Vacuum Systems for Trucks

Get superior high suction suction performance with the Super Duty TVP-300 Series. Designed for septic waste, grease trap pumping, wastewater transfer, construction sites, government applications, facilities management and site remediation services. Available in either stationary, slide in or trailer mounted units.

### Slide-In Units

Slide in units are specialized vacuum systems that connect to the frame of a truck or to the interior of a pick up, box truck or dump truck. There are specific connection points to allow for installation.

### Stationary

Stationary vacuum systems are capable of bolting to a concrete pad, dock or on land.

# BUILD OPTIONS

## CFM Vacuum Power

CFM or cubic feet per minute relates to vacuum suction power. Wastecorp offers several CFM options. Our industry leading standard CFM is 127, 230 CFM, 350 CFM and more are also available. We also offer blower packages for hydro excavation,

127 CFM

---

230 CFM

---

350 CFM

---

## Engine Options

Wastecorp offers electric, gas and diesel power options for Super Duty Vacuum Systems.

Gas

---

Electric

---

Diesel

---

## Dual Compartment Options

Select either waste only tanks or waste plus water compartments.



Wastecorp uses premium steel tanks that stand the test of time. We offer dual compartment waste and water or external polyethylene water tanks (your choice)

## Jetter Options

Expand the capabilities of your system with both waste collection and water jetting function. Jetters are ideal for cleaning catch basins, sewer pipes and general facilities maintenance.



Several jetter packages available to meet your job site needs.

## Optional Equipment



### Rear Manway

Designed to allow for easy maintenance and cleaning of tank interior.



### Work Light Package

Bright LED's for working in dark conditions. Beacon light and traffic diversion arrows (DOT compliant) available.



### Storage Options

Locking storage compartments available depending on the model. Various lockable storage options to help deter theft and vandalism.



### Electric Driven Motor With Control Panel

Using your vacuum pumping system indoors or have a power source? Wastecorp offers an electric model with heavy duty industrial hose reel.

**SUPER DUTY® VACUUM PUMPS**

Designed and Manufactured by Wastecorp Pumps in USA and/or Canada.

Toll-Free: 1.888.829.2783 Email: [info@wastecorp.com](mailto:info@wastecorp.com)

International: +1-201-445-2882

  
**WASTECORP  
Pumps®**

**OEM Manufacturer**