



1000 GALLON CAPACITY. CUSTOM OPTIONS. MOUNT ALMOST ANYWHERE.

Are you looking for a high capacity slide in septic pumper or grease trap waste pumping equipment? Look no further than the TVP-1000 Series slide in unit manufactured by Wastecorp Pumps. With 1000 US gallon capacity you can pump out septic tanks, grease trap waste for larger institutions like hospitals, prisons, college campuses, government buildings and military bases. You can also configure your system with a water jet function or blower package for hydro excavation.

FEATURES:

- Side mount configuration, optional rear or front mount pump
- Several vacuum pump options available
- Heavy duty steel tank with sight eyes and manway options
- Rugged construction with heavy duty frames and axles so your machine will outlast
- Fast tank emptying with reverse flow available
- Premium hoses available in a variety of lengths

THE SUPER DUTY IS MADE FOR:

- Septic waste pumping
- Hydro Excavating*
- Jetting Applications**
- Portable toilet servicing
- General wastewater cleanup
- Clean out car wash sediment pits
- Storm drain, catch basin pumping and cleaning
- Septic tank pumping

TVP-1000 SPECIFICATIONS

Model	TVP-1000-S (127 CFM)	TVP-1000-S (side mount)
Vacuum/Pressure	127 CFM	230 CFM
Typical applications	Grease Trap & Portable Toilets	Septic Tank / Sump Pits /
Part Number	65188-45	65188-43
Tank		
Capacity	1000 US Gallons	
Base Frame	Heavy Duty Fabricated Steel	
Tank Material	A36 Carbon Steel	
Sight Eyes	(2) 5" Glass	
Manway	25" Rear Mount Swing Door	
Hose Rack	(2) Hooks on rear or side of tank	
Engine		
Gas Engine	9 hp Honda/Kohler Gas E-Start	14 hp Honda/Kohler Gas E-Start
Optional Engine	10 hp Kohler Diesel E-Start	17 hp Kohler Diesel E-Start
Power Transmission	Belt Driven	
Hoses		
Suction Hose	30 ft Non-Collapsible with Alum. Camlock Fittings (longer lengths available)	
Discharge Hose	10 ft Layflat with Alum. Camlock Fittings (longer lengths available)	
Port Sizes		
Suction Port Size	2" lever Valve with Camlock	3" Lever Valve with Camlock
Off-Load Port Size	3" Lever Valve with Camlock	4" Lever Valve with Camlock
Suction Vac Wand:	5 ft PVC Pipe with 90° Camlock	
Overall (Approximate)		
Dry Weight (lb):	2800 - 3200 lbs	
Loaded (water)	11130 - 11530 lbs	

DESIGNED AND MANUFACTURED BY WASTECORP PUMPS IN NORTH AMERICA.
 VISIT WASTECORP.COM

TVP-1000 Slide-In Dimensions

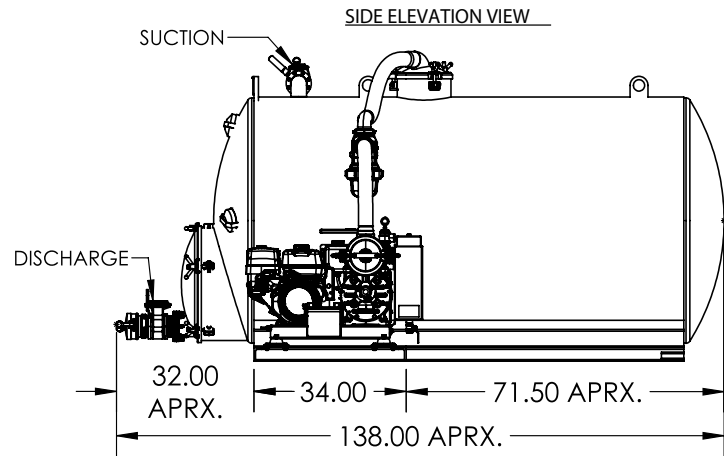
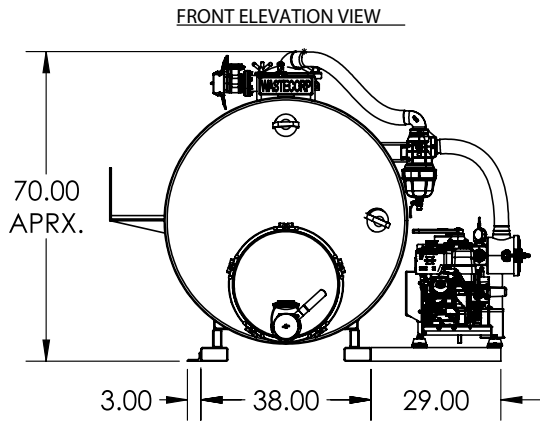

*Not to be used for construction purposes Contact factory

TVP-1000-S, SIDE MOUNTED, 230 CFM DIMENSIONAL DRAWING



TVP-1000 Slide-In Variations



Front, rear or side mounted pump/engine system with hose reel and forklift pockets



Roll-off skid system



Custom colors



Tilt tank for pumping on uneven terrain, hills, slopes or mountainous regions.

BUILD OPTIONS

CFM Vacuum Power

CFM or cubic feet per minute relates to vacuum suction power. Wastecorp offers several CFM options. Our industry leading standard CFM is 127, 230 CFM, 350 CFM and 532 CFM are also available. We also offer blower packages for hydro excavation,

127 CFM

230 CFM

350 CFM

532 CFM

Engine Options

Wastecorp offers electric, gas and diesel power options for Super Duty Vacuum Systems.

Gas

Electric

Diesel

Tank Options

Select either waste only tanks or waste plus water compartments.



Wastecorp uses premium steel tanks that stand the test of time. We offer dual compartment waste and water or external polyethylene water tanks (your choice)

Jetter Options

Expand the capabilities of your system with both waste collection and water jetting function. Jetters are ideal for cleaning catch basins, sewer pipes and general facilities maintenance.



Several jetter packages available to meet your job site needs.

Optional Equipment



Rear Manway

Designed to allow for easy maintenance and cleaning of tank interior.



Custom Tank Positions

Working on a slope or have unique tank positioning requirements? Wastecorp can help with that. We can position the tank at most angles and include ladders as well.



Automated or Spring Loaded Hose Reel

Make retracting and organizing your hoses easier with automatic or spring loaded hose reels. Available in 50, 100 or 150 ft lengths



Electric Driven Motor With Control Panel

Using your vacuum pumping system indoors or have a power source? Wastecorp offers an electric model with heavy duty industrial hose reel.

SUPER DUTY® VACUUM PUMPS

Designed and Manufactured by Wastecorp Pumps in USA and/or Canada.

Toll-Free: 1.888.829.2783 Email: info@wastecorp.com
International: +1-201-445-2882