



1600 GALLON CAPACITY. CUSTOM OPTIONS. MOUNT ALMOST ANYWHERE.

Are you looking for a high capacity slide in vacuum system for wastewater pumping, septic pumping or grease trap waste pumping? Look no further than the TVP-1600 Series slide in unit manufactured by Wastecorp Pumps. With 1600 US gallon capacity you can pump out septic tanks, grease trap waste for larger institutions like hospitals, prisons, college campuses, government buildings and military bases. You can also configure your system with a water jet function or blower package for hydro excavation.

FEATURES:

- Optional side mount, rear mount or front mount pump
- Several vacuum pump options available
- Heavy duty steel tank with sight eyes and manway options
- Rugged construction with heavy duty frames and axles so your machine will outlast
- Fast tank emptying with reverse flow available
- Premium hoses available in a variety of lengths

THE SUPER DUTY IS MADE FOR:

- Septic waste pumping
- Hydro Excavating*
- Jetting Applications**
- Portable toilet servicing
- General wastewater cleanup
- Clean out car wash sediment pits
- Storm drain, catch basin pumping and cleaning

TVP-1600 SPECIFICATIONS

Model	TVP-1600-S (230 CFM)
Vacuum/Pressure	230 CFM
Typical applications	Grease Trap & Portable Toilets Septic Tank / Sump Pits /
Part Number	65822-05
Tank	
Capacity	1600 US Gallons
Base Frame	Heavy Duty Fabricated Steel
Tank Material	A36 Carbon Steel
Sight Eyes	(2) 5" Glass
Manway	25" Rear Mount Swing Door
Hose Rack	(2) Hooks on rear of tank
Engine	
Gas Engine	14 hp Honda/Kohler Gas E-Start
Optional Engine	24 hp Kohler Diesel E-Start
Power Transmission	Belt Driven
Hoses	
Suction Hose	30 ft Non-Collapsible with Alum. Camlock Fittings (longer lengths available)
Discharge Hose	10 ft Layflat with Alum. Camlock Fittings (longer lengths available)
Port Sizes	
	3" Lever Valve with Camlock
Off-Load Port Size	4" Lever Valve with Camlock
Suction Vac Wand:	5 ft PVC Pipe with 90° Camlock
Overall (Approximate)	
Dry Weight (lb):	6500 lbs
Loaded	19000 lbs

DESIGNED AND MANUFACTURED BY WASTECORP PUMPS IN NORTH AMERICA.
VISIT WASTECORP.COM

TVP-1600 Slide-In Dimensions

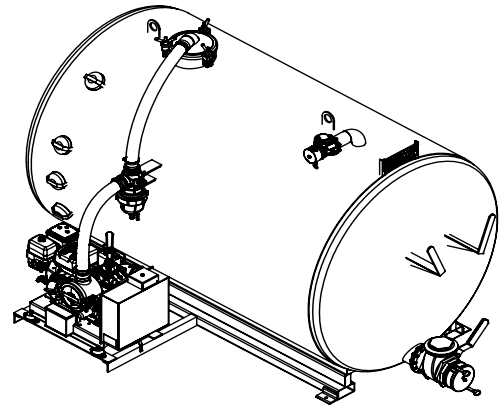
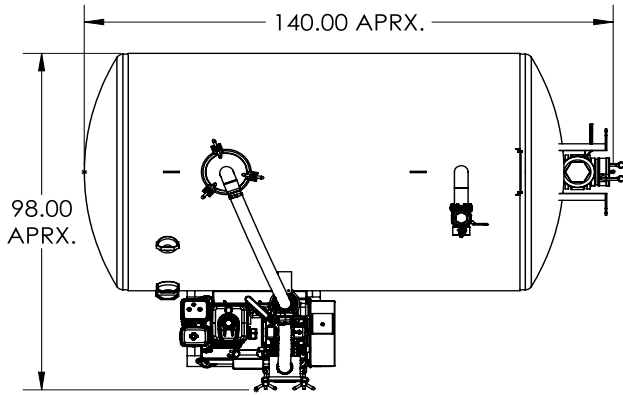

*Not to be used for construction purposes Contact factory

TVP-1600-S, SIDE
MOUNTED, 230 CFM,
DIMENSIONAL DRAWING



TVP-1600 Slide-In Variations



Front, rear or side mounted pump/engine system with hose reel and forklift pockets



Roll-off skid system



Custom colors



Tilt tank for slide in models

BUILD OPTIONS

CFM Vacuum Power

CFM or cubic feet per minute relates to vacuum suction power. Wastecorp offers several CFM options. Our industry leading standard CFM is 127. 230 CFM, 350 CFM and 512 CFM are also available. We also offer blower packages for hydro excavation,

127 CFM

230 CFM

350 CFM

512 CFM

Engine Options

Wastecorp offers electric, gas and diesel power options for Super Duty Vacuum Systems.

Gas

Electric

Diesel

Tank Options

Select either waste only tanks or waste plus water compartments.



Wastecorp uses premium steel tanks that stand the test of time. We offer dual compartment waste and water or external polyethylene water tanks (your choice)

Jetter Options

Expand the capabilities of your system with both waste collection and water jetting function. Jetters are ideal for cleaning catch basins, sewer pipes and general facilities maintenance.



Several jetter packages available to meet your job site needs.

Optional Equipment



Rear Manway

Designed to allow for easy maintenance and cleaning of tank interior.



Work Light Package

Bright LED's for working in dark conditions. Beacon light and traffic diversion arrows (DOT compliant) available.



Storage Options

Fender Mounted locking storage compartment. Various lockable storage options to help deter theft and vandalism.



Tank Ladder

Allows easier access to top of the tank.



Tank Mounted Camera System

Reverse assistance wired into the cab of your truck



Generator (Electric Models)

Have back up power if needed for your electric vacuum trailer.

SUPER DUTY® VACUUM PUMPS

Designed and Manufactured by Wastecorp Pumps in USA and/or Canada.

Toll-Free: 1.888.829.2783 Email: info@wastecorp.com
International: +1-201-445-2882