



## THE ULTIMATE SLIDE-IN VACUUM PUMP SYSTEM IDEAL FOR TRUCK CHASSIS MOUNTS.

If you are a service business looking to add a high suction power vacuum pump system to your fleet, the TVP-800 SL is your ticket to enhanced productivity and long life cycles. With 800 US gallon capacity you can pump out residential septic tanks, grease trap waste for larger institutions like hospitals, prisons, college campuses, government buildings and military bases. You can also configure your system with a water jet function or blower package for hydro excavation.

### FEATURES:

- Side mount configuration, optional rear or front mount pump
- Several vacuum pump options available
- Heavy duty steel tank with sight eyes and man way options
- Rugged construction with heavy duty frames and axles so your machine will outlast
- Fast tank emptying with reverse flow available
- Premium hoses available in a variety of lengths

### THE SUPER DUTY IS MADE FOR:

- Septic waste pumping
- Hydro Excavating\*
- Jetting Applications\*\*
- Portable toilet servicing
- General wastewater cleanup
- Clean out car wash sediment pits
- Storm drain, catch basin pumping and cleaning

# TVP-800-SL SPECIFICATIONS

<b>Model</b>	<b>TVP-800-SL (side mount)</b>
Vacuum/Pressure	230 CFM
Typical applications	Septic Tank / Sump Pits / Grease Trap & Portable Toilets
Part Number	64960-17
<b>Tank</b>	
Capacity	800 US Gallons
Base Frame	Heavy Duty Fabricated Steel
Tank Material	A36 Carbon Steel
Sight Eyes	(2) 5" Glass
Manway	25" Rear Mount Swing Door
Hose Rack	(2) Hooks on rear or side of tank
<b>Engine</b>	
Gas Engine	14 hp Honda/Kohler Gas E-Start
Optional Engine	17 hp Kohler Diesel E-Start
Power Transmission	Belt Driven
<b>Hoses</b>	
Suction Hose	30 ft Non-Collapsible with Alum. Camlock Fittings (longer lengths available)
Discharge Hose	10 ft Layflat with Alum. Camlock Fittings (longer lengths available)
<b>Port Sizes</b>	
Suction Port Size	3" Lever Valve with Camlock
Off-Load Port Size	4" Lever Valve with Camlock
Suction Vac Wand:	5 ft PVC Pipe with 90° Camlock
<b>Overall (Approximate)</b>	
Dry Weight (lb):	2250-2650 lbs
Loaded	8900-9300 lbs

DESIGNED AND MANUFACTURED BY WASTECORP PUMPS IN NORTH AMERICA.  
VISIT [WASTECORP.COM](http://WASTECORP.COM)

## TVP-800-SL Slide-In Dimensions

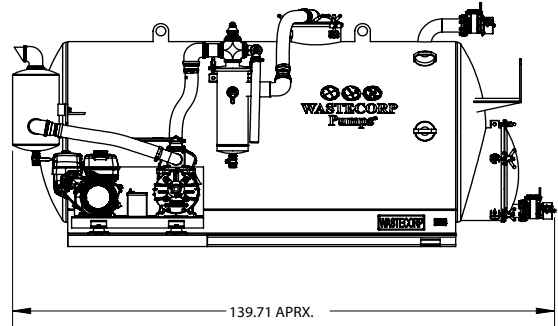
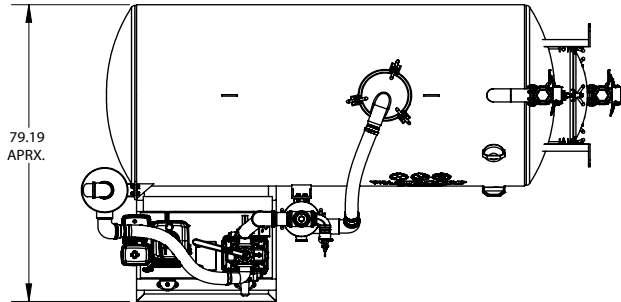

\*Not to be used for construction purposes Contact factory

## TVP-800-SL Slide-In Variations



Front, rear or side mounted pump/engine system with hose reel and forklift pockets



Roll-off skid system



Custom colors



Tilt tank for pumping on uneven terrain, hills, slopes or mountainous regions.

# BUILD OPTIONS

## CFM Vacuum Power

CFM or cubic feet per minute relates to vacuum suction power. Wastecorp offers several CFM options. Our industry leading standard CFM is 127. 230 CFM, 350 CFM and 532 CFM are also available. We also offer blower packages for hydro excavation,

127 CFM

---

230 CFM

---

350 CFM

---

532 CFM

## Engine Options

Wastecorp offers electric, gas and diesel power options for Super Duty Vacuum Systems.

Gas

---

Electric

---

Diesel

## Tank Options

Select either waste only tanks or waste plus water compartments.



Wastecorp uses premium steel tanks that stand the test of time. We offer dual compartment waste and water or external polyethylene water tanks (your choice)

## Jetter Options

Expand the capabilities of your system with both waste collection and water jetting function. Jetters are ideal for cleaning catch basins, sewer pipes and general facilities maintenance.



Several jetter packages available to meet your job site needs.

## Optional Equipment



### Rear Manway

Designed to allow for easy maintenance and cleaning of tank interior.



### Custom Tank Positions

Working on a slope or have unique tank positioning requirements? Wastecorp can help with that. We can position the tank at most angles and include ladders as well.



### Automated or Spring Loaded Hose Reel

Make retracting and organizing your hoses easier with automatic or spring loaded hose reels. Available in 50, 100 or 150 ft lengths



### Electric Driven Motor With Control Panel

Using your vacuum pumping system indoors or have a power source? Wastecorp offers an electric model with heavy duty industrial hose reel.

## SUPER DUTY® VACUUM PUMPS

Designed and Manufactured by Wastecorp Pumps in USA and/or Canada.

Toll-Free: 1.888.829.2783 Email: [info@wastecorp.com](mailto:info@wastecorp.com)

International: +1-201-445-2882