

SUPER DUTY® VACUUM PUMPS

TVP-450™ Series

Tilt-N-Go™ Hydraulic Tilt System

CALL 1-888-829-2783

WASTECORP
Pumps®



THE TVP-450 TILT-N-GO EMPOWERS YOUR ABILITY TO GET THE JOB DONE.

Looking for the ultimate vacuum trailer with tilt tank function? Look no further with Wastecorp Pumps' Super Duty TVP-450 Tilt-N-Go pump system. Designed with a hydraulic tilt function and optional power rear door, you can stay productive throughout the workday. Several vacuum suction power and engine sizes are available.

FEATURES

- Premium DOT compliant trailer system electric brakes and lighting package
- 127 CFM - 532 CFM vacuum pumps available
- Heavy duty steel tank with sight eyes and 36" manway
- Rugged construction with heavy duty frames and axles so your machine will outlast.
- Automated hydraulic tilt function to empty or clean out tank
- Premium hoses available in a variety of lengths

THE SUPER DUTY IS MADE FOR:

- Septic waste pumping
- Grease trap waste pumping
- Portable toilet servicing
- General wastewater cleanup
- Clean out car wash sediment pits
- Storm drain, catch basin pumping and cleaning
- Septic tank pumping

DESIGNED AND MANUFACTURED BY WASTECORP PUMPS IN NORTH AMERICA.
VISIT WASTECORP.COM

TVP-450 Tilt Tank Specifications

| | |
|------------------------------|--|
| Model | TVP-450-DT (230 CFM) |
| Vacuum/Pressure | 230 CFM |
| Typical applications | Septic tanks / sump pits / grease trap/ construction waste/ general wastewater |
| Part Number | 65921-60 |
| Tank | |
| Capacity | 500 US Gallons |
| Base Frame | Heavy Duty Fabricated Steel |
| Tank Material | A36 Carbon Steel |
| Sight Eyes | (2) 5" Glass |
| Manway | 25" Rear Mount Swing Door |
| Hose Rack | (2) Hooks on rear of tank |
| Engine | |
| Gas Engine | 14 hp Honda/Kohler Gas E-Start |
| Optional Engine | 17 hp Kohler Diesel E-Start |
| Power Transmission | Belt Driven |
| Trailer | |
| Trailer Specs | Tandem axle, e-brakes, jack stand, LED lighting, alum. checker plate deck |
| Hitch | Select: 2" Ball, 2 5/16" ball, 3" Pintle |
| Wheels | Galvanized spoke |
| Tires | ST225/75R15 |
| Jackstand | 7,000 lbs |
| Trailer and brake supply | DOT approved 7 way connector |
| Lighting System | DOT approved LED |
| Safety Chains | DOT approved zinc-plated w/two clevis grab hooks |
| Hoses | |
| Suction Hose | 30 ft Non-Collapsible with Alum. Camlock Fittings (longer lengths available) |
| Discharge Hose | 10 ft Layflat with Alum. Camlock Fittings (longer lengths available) |
| Port Sizes | |
| | 2" Lever Valve with Camlock |
| Off-Load Port Size | 3" Lever Valve with Camlock |
| Suction Vac Wand: | 5 ft PVC Pipe with 90° Camlock |
| Overall (Approximate) | |
| Dry Weight (lb): | Call |
| Loaded (water) | Call |
| GVWR | Call |

TVP-450 Tilt Tank General Dimensions

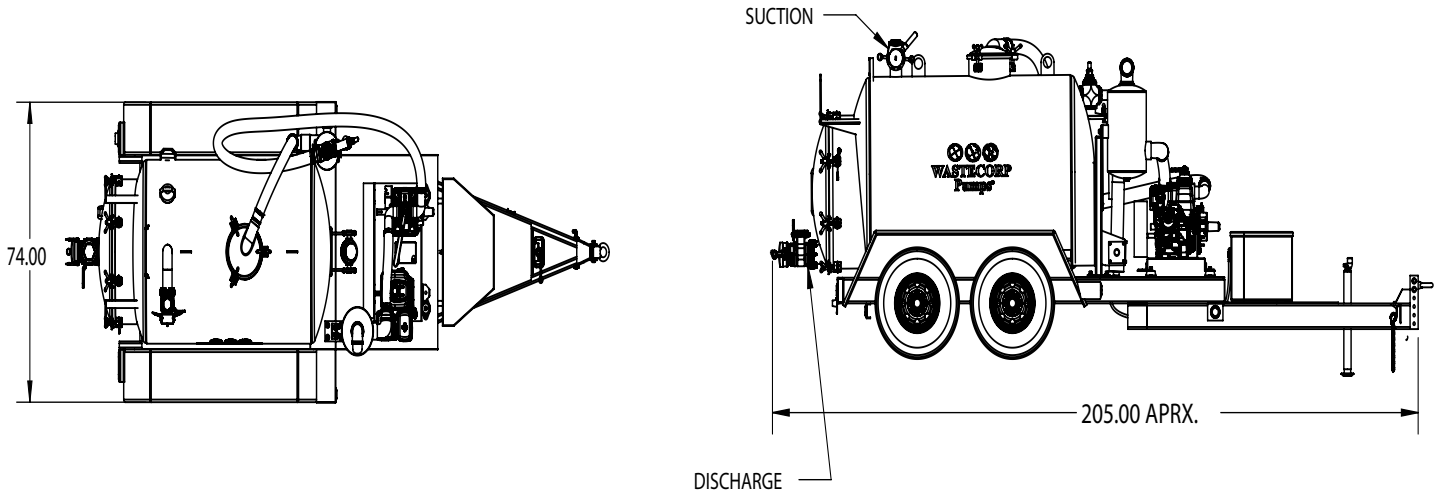

Ship to you or pick up at our factory



The ultimate in quality and dependability



Designed for multiple applications

BUILD OPTIONS

CFM Vacuum Power

CFM or cubic feet per minute relates to vacuum suction power. Wastecorp offers several CFM options. Our industry leading standard CFM is 127, 230 CFM, 350 CFM and higher are also available. We also offer blower packages for hydro excavation,

127 CFM

230 CFM

350 CFM

Engine Options

Wastecorp offers electric, gas and diesel power options for Super Duty Vacuum Systems.

Gas

Electric

Diesel

Dual Compartment Options

Select either waste only tanks or waste plus water compartments.



Wastecorp uses premium steel tanks that stand the test of time. We offer dual compartment waste and water or external polyethylene water tanks (your choice)

Jetter Options

Expand the capabilities of your system with both waste collection and water jetting function. Jetters are ideal for cleaning catch basins, sewer pipes and general facilities maintenance.



Several jetter packages available to meet your job site needs.

Optional Equipment



Rear Manway

Designed to allow for easy maintenance and cleaning of tank interior.



Work Light Package

Bright LED's for working in dark conditions. Beacon light and traffic diversion arrows (DOT compliant) available.



Storage Options

Locking storage compartments available depending on the model. Various lockable storage options to help deter theft and vandalism.



Tank Mounted Camera System

Wireless reverse assistance making maneuvering your job site easier.

SUPER DUTY® VACUUM PUMPS

Designed and Manufactured by Wastecorp Pumps in USA and/or Canada.

Toll-Free: 1.888.829.2783 Email: info@wastecorp.com

International: +1-201-445-2882

www.wastecorp.com