

Mud Sucker®
Diaphragm Pumps

32FA-EC Series

Heavy Duty
Diaphragm Pumps

32FA-EC™
32FA-EC-C™

FEATURES

2" Connection size

Pump up to 50 GPM

Transfer spherical solids up to
1½" or 50% by volume

Suction capabilities up to 100'

Heavy duty diaphragm

Multiple drive options and
industry specific components



WASTECORP.
Pumps®

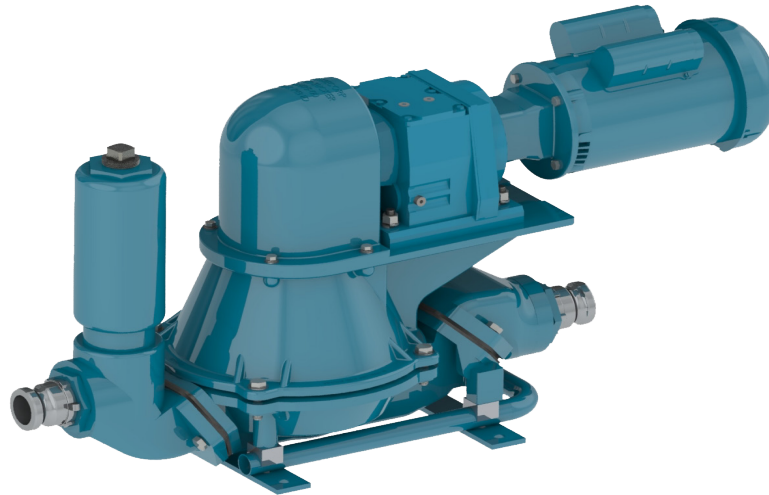

Up to 50 GPM Pumping Capabilities. The Ultimate Heavy Duty Diaphragm Pump

If you're pumping wastewater, slurry, waste oil, septic waste or food processing renderings, then you need to take a close look at the Mud Sucker 32FA Series designed and manufactured by Wastecorp Pumps. This is a heavy duty flapper valve style diaphragm pump that can run dry and transfer up to 50 GPM with up to 100' of suction*

Make Pumping Tough Fluids Easier

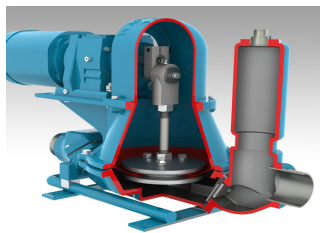

EXCLUSIVE CONTOURED VELOCITY CHANNEL

Only with Mud Sucker pumps do you get an industry exclusive velocity channel that enhance the flow of fluids and reduces the chance for clogging



MULTIPLE DRIVE OPTIONS

We understand the needs of your industry. That's why we offer several high performance drives from the industry's leading manufacturers including Siemens, SEW, Baldor and more



CONFIGURED FOR YOUR FACILITY

With custom mounting systems available and your choice of in-line or standard piping systems, you get a pump designed for your facility.

WHAT THIS MEANS TO YOU.

The pump adapts to your unique fluid handling environment. Experience increased productivity and less downtime.

Get the explosion proof, variable speed, single or three phase drive that works best for you.

Get solutions for tight spaces, piping arrangements and industry specific components that you need to get the job done right the first time.

MUD SUCKER® DIAPHRAGM PUMPS THE PUMP WITH ATTITUDE.

wastecorp.com

*Figures based on pumping water. Flow rate may be affected by percentage of solids, thickness of fluid, elevation and other factors. Let your Wastecorp representative know what you are pumping and how far you need to discharge the fluid before ordering.

Mud Sucker® Diaphragm Pumps

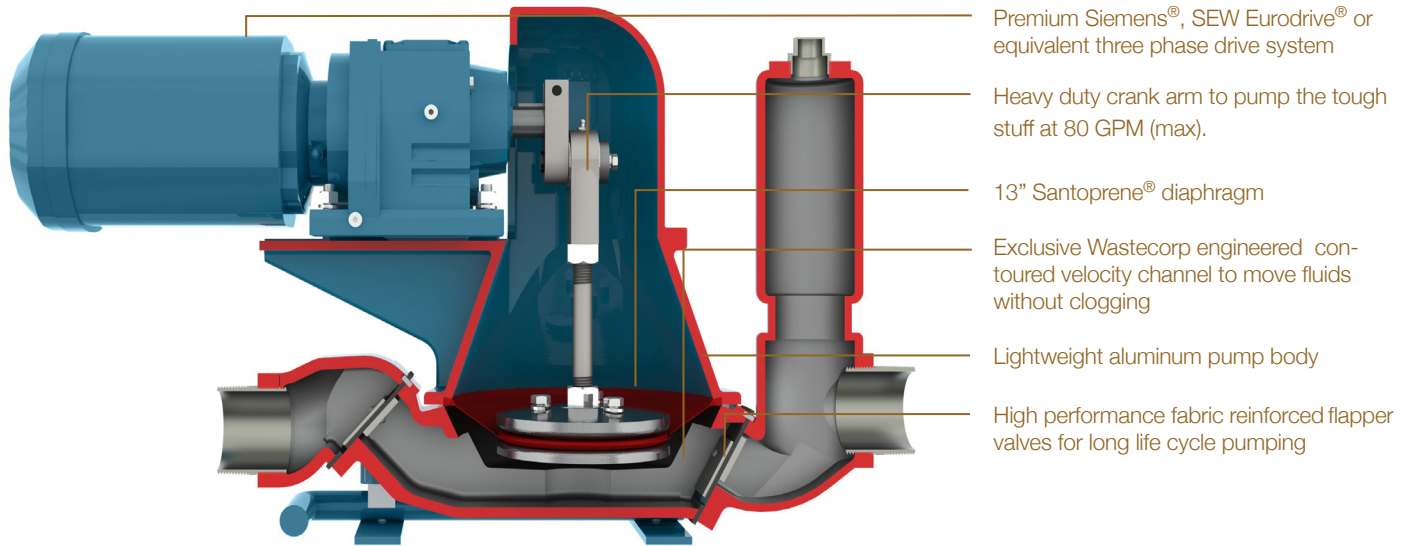

- Premium Siemens®, SEW Eurodrive® or equivalent three phase drive system
- Heavy duty crank arm to pump the tough stuff at 80 GPM (max).
- 13" Santoprene® diaphragm
- Exclusive Wastecorp engineered contoured velocity channel to move fluids without clogging
- Lightweight aluminum pump body
- High performance fabric reinforced flapper valves for long life cycle pumping

Mud Sucker 32FA Series is manufactured in North America (USA/Canada). Country/region specific models are available worldwide.

Performance Range

Max. capacity	50 GPM
Max. suction distance	100' horizontal
Max. discharge head	50' vertical or 300' horizontal
Solids handling	1½" dia or 50% by volume

Pump Specifications

Suction inlet/outlet size	2"x2" (female threaded)
Max. liquid temperature	140°F (60°C) continuous*
Pump body casing	Aluminum A356, heat treated
Diaphragm	13" OD TPE Santoprene® severe duty
Flapper valves	HNBR w/ reinforced tire cord
Gear reducer	SEW Eurodrive/Siemens
Crankarm	AISI 1045 HR steel
Pump rod	AISI 12L14 carbon steel
Pump operating speed	60 RPM

Motor Options

Description	Part No.	Motor Option
Standard motor (TEFC)	65156-10	2 hp, 1800RPM/3/60/230-460V TEFC
Single Phase (TEFC)	65156-00	2 hp, 1800RPM/1/60/115-230V TEFC
Explosion Proof (Three phase, TEXP)	65156-20	2 hp, 1800RPM/3/60/230-460V TEXP
Explosion Proof (Single phase), TEXP	65156-30	2 hp, 1800RPM/1/60/115-230V TEXP

Popular 32FA Series Applications

- Pacified Chemical Sludge
- Lime Slurry
- Waste Oil Sludge
- Fiberboard Filler
- Raw Latex
- Clay Slurries
- Cruise Ship Wastes
- Food Processing Waste (pork, cattle, fish, fruit, vegetable, dairy, poultry)
- Paper Pump Transfer
- Explosive Jelly
- Paint Transfer
- Polymer Transfer
- Ship Bilge Transfer
- Metal Slurry Transfer
- Holding Tank Transfer
- Coal Slurry
- Hog Fat
- Chemical Filler Materials
- Chocolate Waste Product Transfer
- Portable Trash/Clean-up
- Sludge Recovery (tanker mounted units)
- Ferric Chloride
- Mobile Dewatering
- Feed Pump
- Lagoon Cleaning
- Golf Courses
- Harbor Pumps
- Federal/Military
- Railroad Tanker Cleaning
- Thickened Sludge Transfer
- Scum Feed Pumps
- Portable Clean-up Pump Sets
- Centrifuge Feed Pumps
- Lime Slurry Transfer
- Lagoon Dredging
- Septic Transfer
- State/Federal Parks & Recreation
- Emergency Management Response

* Consult factory if fluid temperature exceeds 140° F



WASTECORP.
Pumps®

OEM Manufacturer

Mud Sucker® Diaphragm Pumps

Toll-Free: 1.888.829.2783 Email: info@wastecorp.com

Mud Sucker 32FA Series pumps are specified for the following industries and applications: wastewater, septic waste, waste oil pumping, agricultural, aquaculture farming, farms, food processing, oil, gas, shale, select chemicals, pulp and paper mills, marine pumping applications, landfills, dewatering, biodiesel production and others. Mention your application to your technical support representative at the time of order. Before operating your diaphragm pump, read, understand and follow all instructions in the manual and on the pump. Specifications and programs are accurate at the time of publication but subject to change without notice. Images may not reflect dealer inventory and/or unit specifications. Wastecorp, Mud Sucker and globes are trademarks of Wastecorp Pumps Inc. No reproduction of this document without permission. © Wastecorp.

ATTACHMENTS

Enhanced pump out productivity with your Mud Sucker diaphragm pump can be as easy as adding a few simple accessories. So if you need to suck up dirt and debris, need a mess free pump out, or have a heavier duty dewatering application, the right accessories can enhance your fluid handling one step further.

	Part no.	Description		Part no.	Description
	60462-00	Camlock fitting 2" alum. male adapter MNPT		61316-00	Wheel mount kit with handles (In-line)
	62975-00	3-way brass valve w/ aluminum camlocks (discharge only)		62732-00	Wheel mount kit with handles (perpendicular)
	61287-00	Basic spare parts kit (diaphragm and flappers)		61346-00	Mobility package (stationary) lifting bars
	61286-00	Comprehensive spare parts kit (diaphragm, flappers gaskets, weights and hardware)		64658-10	Professional Wagon kit, 16" pneumatic tires
	64970-10	Air chamber (discharge side). Pulsation dampening		61492-00	Transformer start/estop, w/ Nema 12 overload protection
	61951-00	Non-collapsible EPDM hose 2"x30'. Camlocks included		Various	Wet section coatings for specific applications
	51333-10	Discharge hose, lay flat (brown) 2"x50'. Camlocks included		99999-99	SEW Movimot™ 24V key pad speed control
	34383-00	Stainer, round hole (solids) 2" FNPT		Various	Waste containment system with tank, hoses, trailer and pump
	60536-00	2" round hole strainer for non-clog performance		60536-00	Clear swing check valve 2" FPTx FPT