

Mud Sucker®
Diaphragm Pumps

3FA-M Series

Heavy Duty
Diaphragm Pumps

3FA-M™

3FA-M-C™

FEATURES

3" Connection size

Pump up to 80 GPM

Transfer spherical solids up to
2-1/4" or 50% by volume

Suction capabilities up to 100'

13" Heavy duty diaphragm

6 hp gas engine



WASTECORP
Pumps®



Power and Performance for The Long Haul.

If you have an outdoor pumping job that requires a heavy duty pump with capabilities up to 80 GPM, look no further than the Mud Sucker 3FA-M Series. This premium diaphragm pump product is designed and manufactured by ISO 9001 certified pump manufacturer Wastecorp Pumps. This is a heavy duty flapper valve style diaphragm pump that can run dry and pump up to 100' of suction*

Make Pumping Tough Fluids Easier

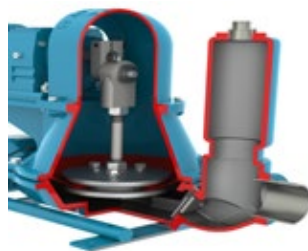

EXCLUSIVE CONTOURED VELOCITY CHANNEL

Only with Mud Sucker pumps do you get an industry exclusive velocity channel that enhances the flow of fluids and reduces clogging.



OPTIONAL AUTO-START FEATURE

The 3FA-M is available with an optional electronic start feature on most gas and diesel models.



DESIGNED FOR THE TOUGH STUFF

Tough fluid handling jobs call for better equipment and the 3FA-M delivers. Plus, you get more attachment options than ever before.

WHAT THIS MEANS TO YOU.

The pump adapts to your unique fluid handling environment. Experience increased productivity and less downtime.

Start your pump out quickly with your choice of gas or diesel engine.

Helps you stay productive with pump technology and attachments designed with you in mind.

MUD SUCKER® DIAPHRAGM PUMPS THE PUMP WITH ATTITUDE.

wastecorp.com

*Figures based on pumping water. Flow rate may be affected by percentage of solids, thickness of fluid, elevation and other factors. Let your Wastecorp representative know what you are pumping and how far you need to discharge the fluid before ordering.

Mud Sucker® Diaphragm Pumps

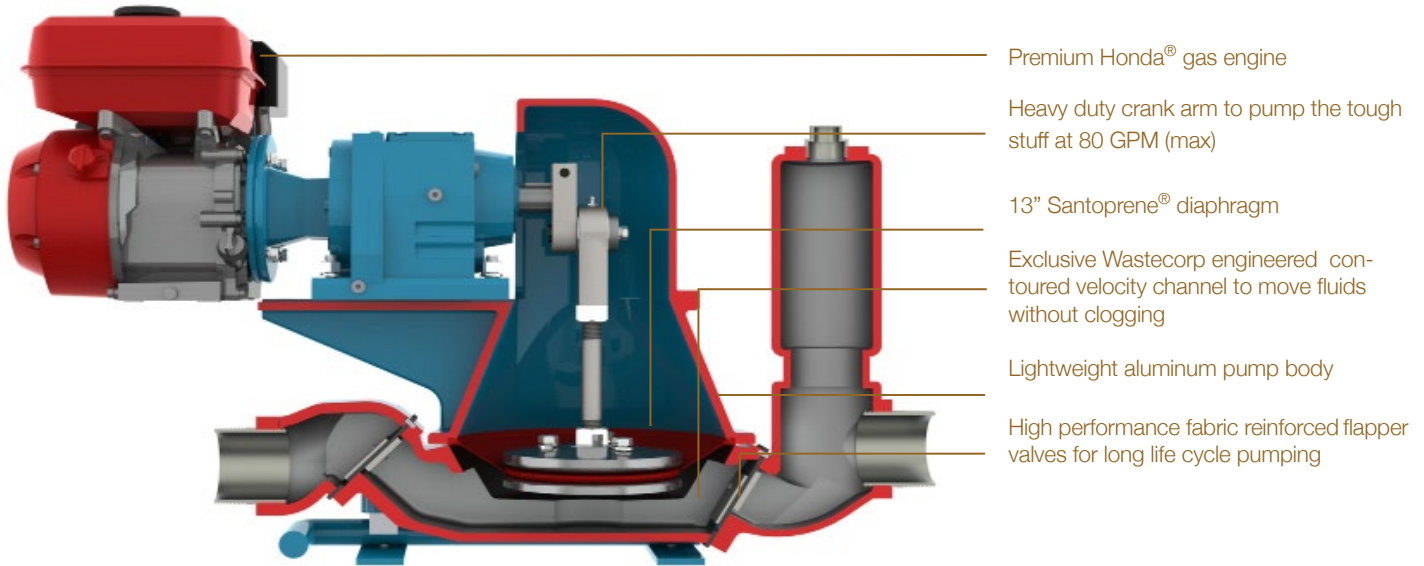

Premium Honda® gas engine

Heavy duty crank arm to pump the tough stuff at 80 GPM (max)

13" Santoprene® diaphragm

Exclusive Wastecorp engineered contoured velocity channel to move fluids without clogging

Lightweight aluminum pump body

High performance fabric reinforced flapper valves for long life cycle pumping

Manufactured in North America. Country/region specific models are available worldwide.

Performance Range

Max. capacity	80 GPM
Max. suction lift	25' vertical or 100' horizontal
Max. discharge head	50' vertical or 300' horizontal
Solids handling	2.25" dia or 50% by volume

Pump and Motor Specifications

Suction inlet/outlet size	3"x3"
Max. liquid temperature	140 °F (60 °C) continuous
Pump body casing	Aluminum (ASTM A356)
Diaphragm	13" dia TPE Santoprene® Severe duty
Flapper valves	HNBR Reinforced
Gearbox	SEW Eurodrive or Siemens
Rod end bearing body	Cast iron, protective coated for corrosion resistance

Pump Models

Description	Part No.
Stationary unit, gas engine	66596-30
Wheel kit, gas engine	66596-35

* Consult factory if fluid temperature exceeds 140 °F

Mud Sucker® Diaphragm Pumps

Toll-Free: 1.888.829.2783 Email: info@wastecorp.com

WASTECORP
Pumps®

OEM Manufacturer

Mud Sucker pumps are specified for the following industries and applications: Federal and military, agricultural, aquaculture farming, farms, food processing, oil, gas, shale, select chemicals, pulp and paper mills, marine pumping applications, waste oil pumping, landfills, dewatering, biodiesel production, public works and others. Mention your application to your technical support representative at the time of order. Before operating your diaphragm pump, read, understand and follow all instructions in the manual and on the pump. Specifications and programs are accurate at the time of publication but subject to change without notice. Images may not reflect dealer inventory and/or unit specifications. Wastecorp, Mud Sucker and globes are trademarks of Wastecorp Pumps Inc. No reproduction of this document without permission. © Wastecorp 2025.

Mud Sucker 3FA Series General Dimensions

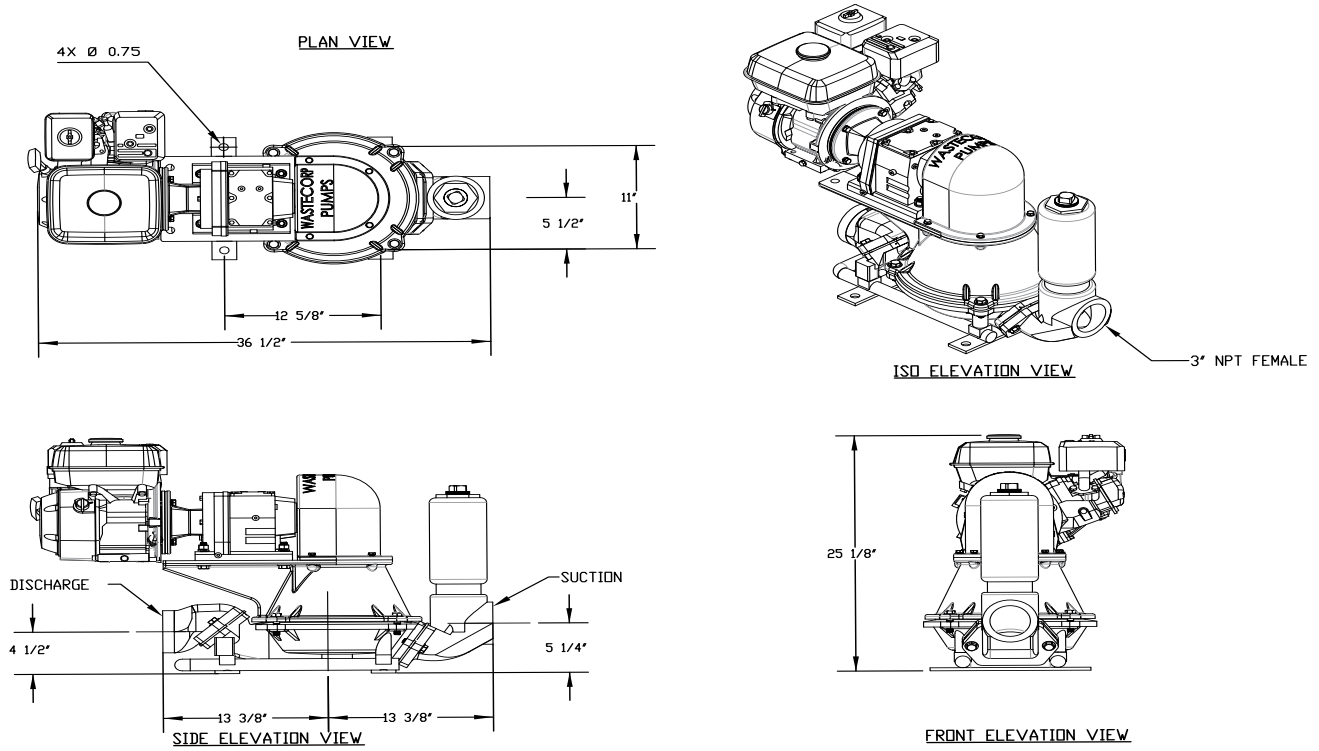



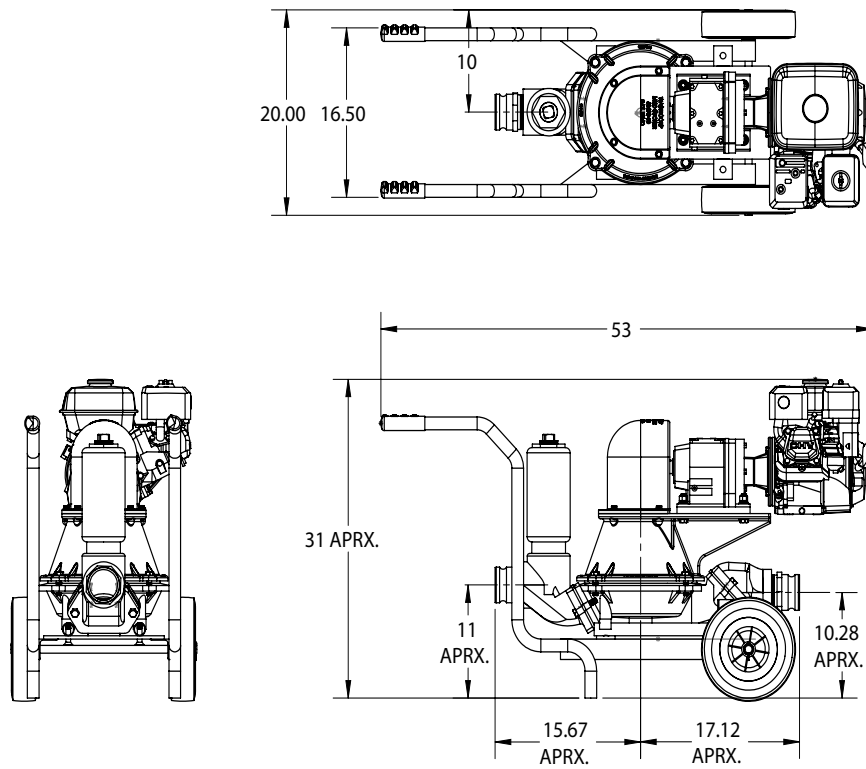







Mud Sucker 3FA Series (Wheel Kit Option) General Dimensions



ACCESSORIES

Enhanced pump out productivity with your Mud Sucker diaphragm pump can be as easy as adding a few simple accessories. If you need to suck up dirt and debris, need a mess free pump out, or have a heavier duty dewatering application, the right accessories can enhance your fluid handling one step further.

Part no.	Description	Part no.	Description
 61287-00 61287-10	Basic spare parts kit (diaphragm and flappers). Santoprene (red) P/N: 61287-00. Neoprene black P/N: 61287-10	 61286-00 61286-10	Comprehensive spare parts kit (diaphragm, flappers gaskets, weights and hardware) Santoprene (red) P/N: 61286-00. Neoprene black P/N: 61286-10
 60466-00	Camlock fitting 3" alum. (Part A) male adapter x female NPT	 61316-00	Wheel mount kit with handles (In-line)
 34383-00	Strainer, square hole (solids) 3" FNPT	 60581-00	Strainer (Non-clog) round hole
 69999-99	Mobility package (stationary) lifting bars	 61292-00	Professional Wagon kit, 16" pneumatic tires
 61605-00	Air chamber (discharge side). Pulsation dampening	 51054-00	Non-collapsible EPDM hose 3"x20'. Camlocks included. Longer lengths available
 51314-10	Discharge hose, lay flat (brown) 3"x10'. Camlocks included. Longer lengths available		