

**MUD SUCKER®**  
**DIAPHRAGM PUMPS**

# FAC-M-DD™ Series

Engine Driven  
Double Diaphragm  
Pumps

3FAC-M-DD™

## FEATURES

Pump up to 160 GPM

Runs dry without damage

Positive displacement pump

Transfer solids up to 2¼" or  
50% by volume

Cast iron pump body

13" diaphragms (x2)

High performance EPDM  
flapper valves (clack)



**WASTECORP.**  
**Pumps®**

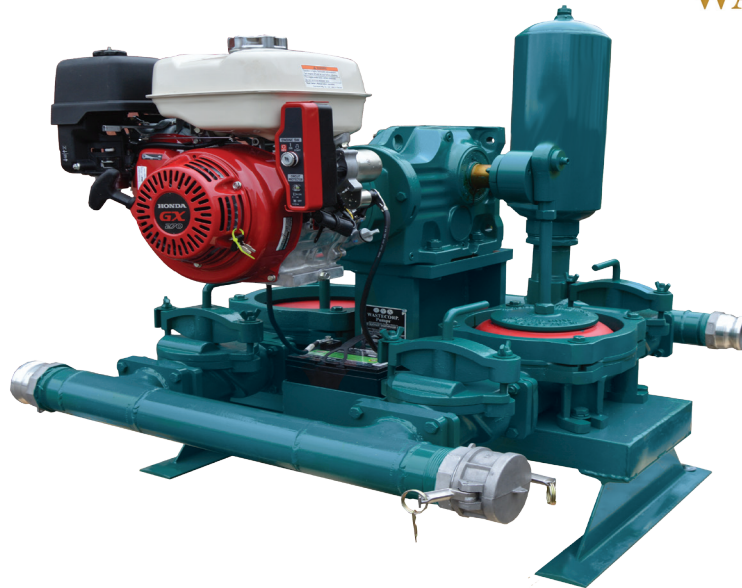

## PUMP POWER AND DURABILITY UNITE. THE MUD SUCKER 3FAC-M-DD.

Wastecorp's latest double diaphragm pump, the Mud Sucker® 3FAC-M-DD™ is an advanced technology pump to help you pump the tough stuff. With a redesigned flapper valve system, you can access the suction and discharge internals with the twist of a handle. In seconds you can inspect the area, change the flappers quickly and get back to business.

Select from Honda gas or diesel engine options to get the right pump for your application. With the widest selection of accessories and custom configurations you get the exact pump out you're looking for without long lead times.

### Double Diaphragm Pumps With Advanced Flapper Technology

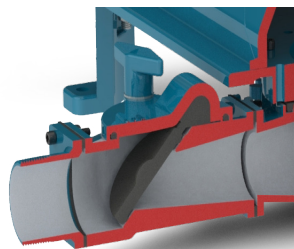

#### Easy Flapper Access

Access the suction and discharge in seconds. With the twist of a handle you can inspect the suction and discharge or replace flappers.

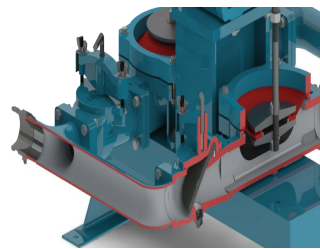

#### Heavy Duty Design

Make no mistake, all double diaphragm pumps are not alike. The Mud Sucker features a cast iron pump body with premium components.

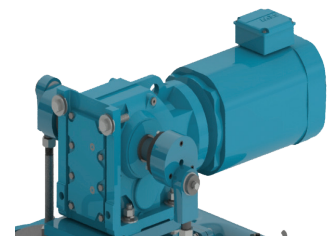

#### TOP Rated Drive Systems

Top rated drive systems available Honda gas or diesel engines.

### WHAT THIS MEANS TO YOU.

Heavy duty EPDM flappers help you pump the tough stuff like no other diaphragm pump.

Get long life cycles and improve your pumping productivity. Spare parts are affordable and are easy to change.

Enhanced performance with engines designed for your pump helps you take advantage of all the Mud Sucker pump can do for you

## Double Diaphragm Pumps With Advanced Flapper Technology

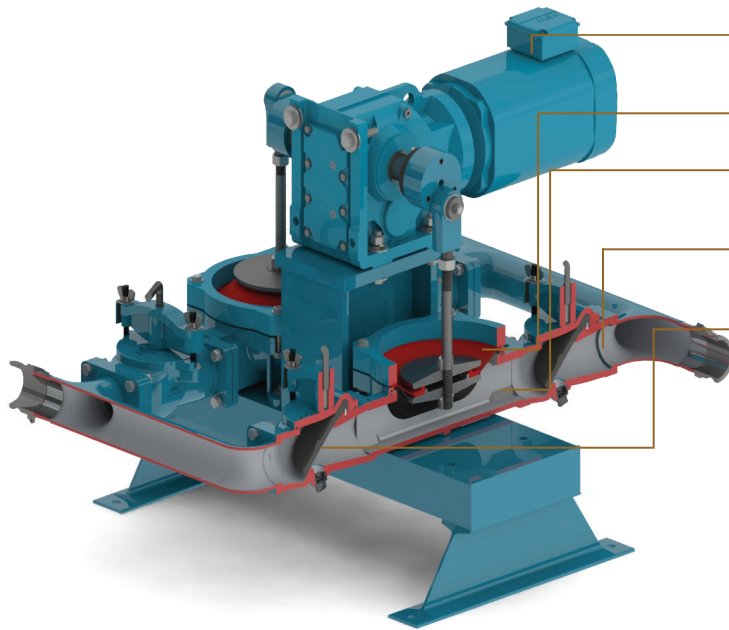

Premium Siemens®, SEW Eurodrive® or equivalent drive system

13" Santoprene® diaphragm

Exclusive Wastecorp engineered velocity channel to move fluids without clogging

Pump Internals available with industry specific components

**Access flappers in seconds with the exclusive Mud Sucker flapper valve system.**

Mud Sucker electric double diaphragm pumps are manufactured in North America. Country/region specific models are available worldwide.

### Performance Range

Max. capacity*	160 GPM
Max. Suction lift	25' vertical or 75' horizontal
Max. discharge head	50' vertical or 300' horizontal
Solids handling	2.250" dia or 50% by volume

### Pump Specifications

Suction inlet/outlet size	3"x3"
Max. liquid temperature	140°F (60°C) continuous
Pump body casing	Cast iron
Diaphragm	13" dia TPE Santoprene® Severe duty
Flapper valves	EPDM
Gearbox/Motor	SEW Eurodrive/Siemens
Ultimate radial static load capacity	9,000 Lbs

### Motor Specifications

Description	Part No.
9 hp Honda gas engine w/gear reducer (e-start)	64995-20
9.1 hp Kohler diesel engine (e-start)	64995-30

### Dimensional Drawing\*\*

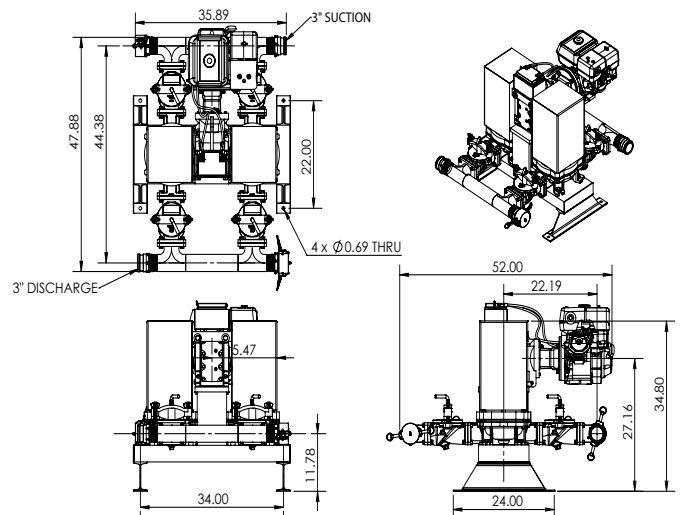

### Performance Curve

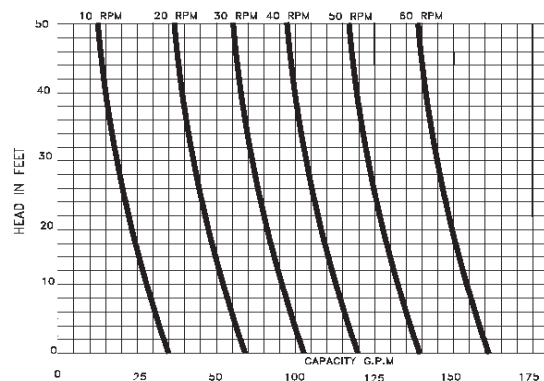











\*Based on pumping water. \*\*Drawing not to be used for construction purposes.

Double Diaphragm Pumps With  
Advanced Flapper Technology



# ACCESSORIES

Part no.	Description	Part no.	Description
 19022-00	<b>Recommended!</b> Pressure relief valve, bronze set at 40 psi	 61292-00	ATV wheel kit. Tow with most makes of ATVs.
 65214-00	Basic spare parts kit (diaphragm and flappers)	 60466-00	Camlock fitting 3" alum. male adapter MNPT
 65066-00	Comprehensive spare parts kit (diaphragm, flappers gaskets, weights and hardware)	 64970-00	Air chamber assembly for pulsation dampening
 60723-00	Non-collapsible EPDM hose 3"x20'. Camlocks included	 Various	Wet section coatings for specific applications
 51334-10	Discharge hose, lay flat (brown) 3"x50'. Camlocks included	 61245-00	Clear swing check valve 3" FPTxFPT

## Mud Sucker® Diaphragm Pumps

Toll-Free: 1.888.829.2783 Email: [info@wastecorp.com](mailto:info@wastecorp.com)  
Website: <http://www.wastecorp.com>

  
**WASTECORP.**  
**Pumps®**  
OEM Manufacturer