

SLUDGE PRO®
DOUBLE DISC PUMPS
4DDWP-SS™

BENEFITS

TRANSFER FROM
0-250 GPM

MAX. HEAD TO 184'
(80 PSI)

NO REGULAR
MAINTENANCE
REQUIRED

TWO YEAR LIMITED
WARRANTY*

IDEAL FOR ABRASIVE,
VISCOUS AND SHEAR
SENSITIVE MEDIA

RUNS DRY = NO DAMAGE

SELF PRIMING PUMP

HIGHER OPERATING
PRESSURE

NEXT GENERATION DISC
PUMP TECHNOLOGY

*Contact factory for warranty details.



Patent Pending

**THE WAIT IS OVER FOR A MORE ADVANCED
DOUBLE DISC PUMP.**

Sludge Pro® double disc pumps are designed for a wide range of slurry and sludge process applications for the municipal, industrial, chemical and food processing industries. These durable leak-free pumps are self priming and can run dry without damage for uncompromising pumping reliability. Select from standard direct drive, belt driven, air, hydraulic and engine drive systems.

SLUDGE PRO® 4DDWP - DOUBLE DISC PUMPS



Advanced Disc Pump Technology

- Seal-less, glandless & leak free design
- OSHA compliant Guard
- Over six models to select from



Innovative Trunnion Options

Not all pumping applications are alike, that's why Wastecorp offers you the right elastomer for your application including:

- Santoprene®
- Teflon®
- Buna-N®
- Nordel®
- Viton®
- Neoprene



Pressure Sensor Assembly

Provides safe protection against dead heading, closed valves or other discharge blockages that can damage the pump. Also permits direct charging of pulsation dampener and access for cleaning.

CUT AWAY

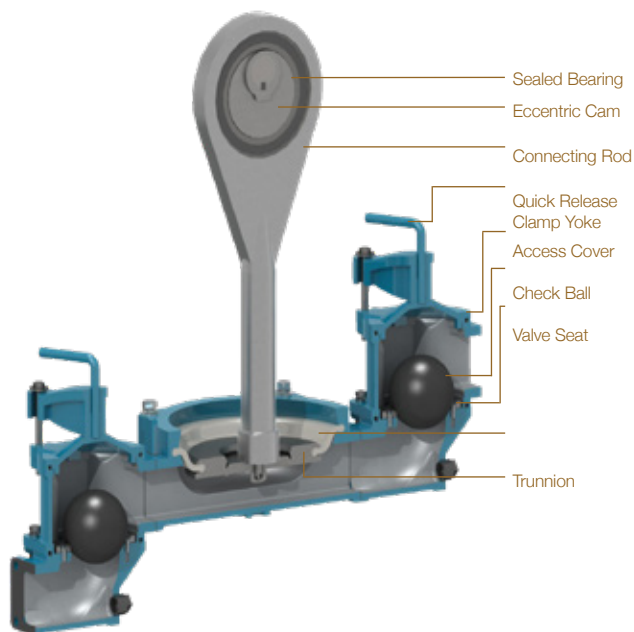

TECHNICAL SPECIFICATIONS

Model	Sludge Pro® 4DDWP
Connection Size	4" 150# Flanged
Typical Flow Range	0-250 GPM
Solids Handling	Max 1¾"
Displacement	2.28 gal/rev
Max. Suction Lift	25'
Max. Discharge Head	184' (80 psi) (5.1 bar)
Max. Liquid Temp.	350°F (176°C)
Operating Speed	up to 110 RPM

MATERIALS OF CONSTRUCTION

	Standard	Optional
Trunnion	Neoprene (TPE) 0°F to 200°F	Santoprene -40°F to +225°F Buna-N® +10°F to +180°F Viton® -40°F to +350°F Teflon® (PTFE) +40°F to +220°F Nordel® -60°F to +280°F
Discs	Ductile Iron, ASTM A 536, Grade 65-45-12	
Ball Valve	Urethane	Teflon®
Sectionalized Construction	Cast Iron ASTM A48 Class 30	See Coating Options Below
Eccentric Cam	Ductile iron ASTM A 536, Grade 65-45-12	
Drive Shaft	400 Series SS	
Connecting Rod	Ductile iron ASTM A 536, Grade 65-45-12	
Base Frame	Heavy Duty Fabricated Steel	304SS, Galvanized Steel, 316 SS

DRIVE SYSTEM OPTIONS

Direct Dive	Electric Motor
Optional	Air, hydraulic, belt driven
Engine Driven	Gas or diesel

Note: Consult factory for applications exceeding maximum pressure and/or temperature indicated.

WETTED CASTING COATING OPTIONS

Xylan, ETFE / PTFE, Dura-S, Nitrile, Neoprene, Nordel, Viton, Hypalon

SLUDGE PRO® DOUBLE DISC PUMPS
4DDWP™ Series



**WASTECORP
Pumps®**

APPROXIMATE PUMP DIMENSIONS

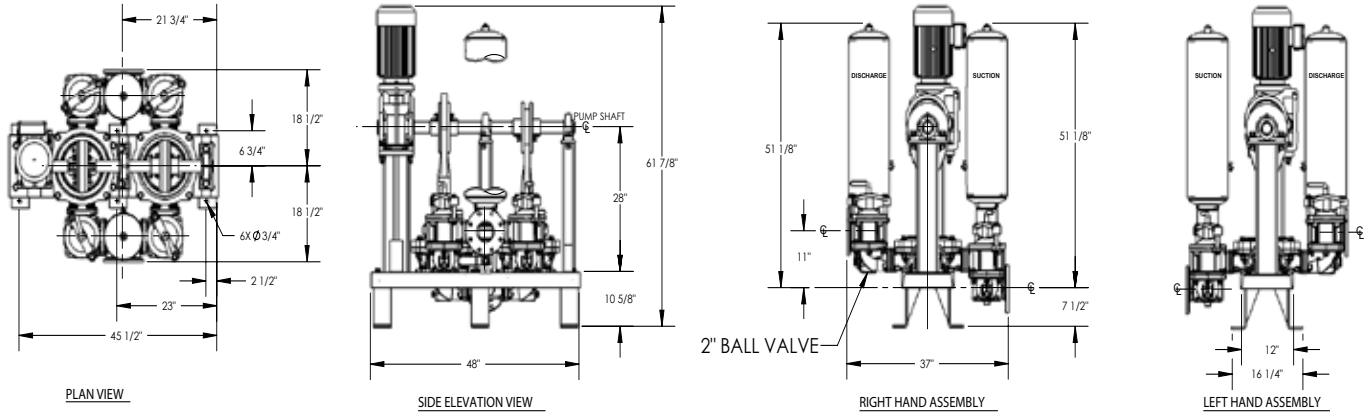

PUMP CURVE

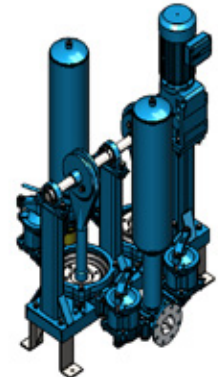
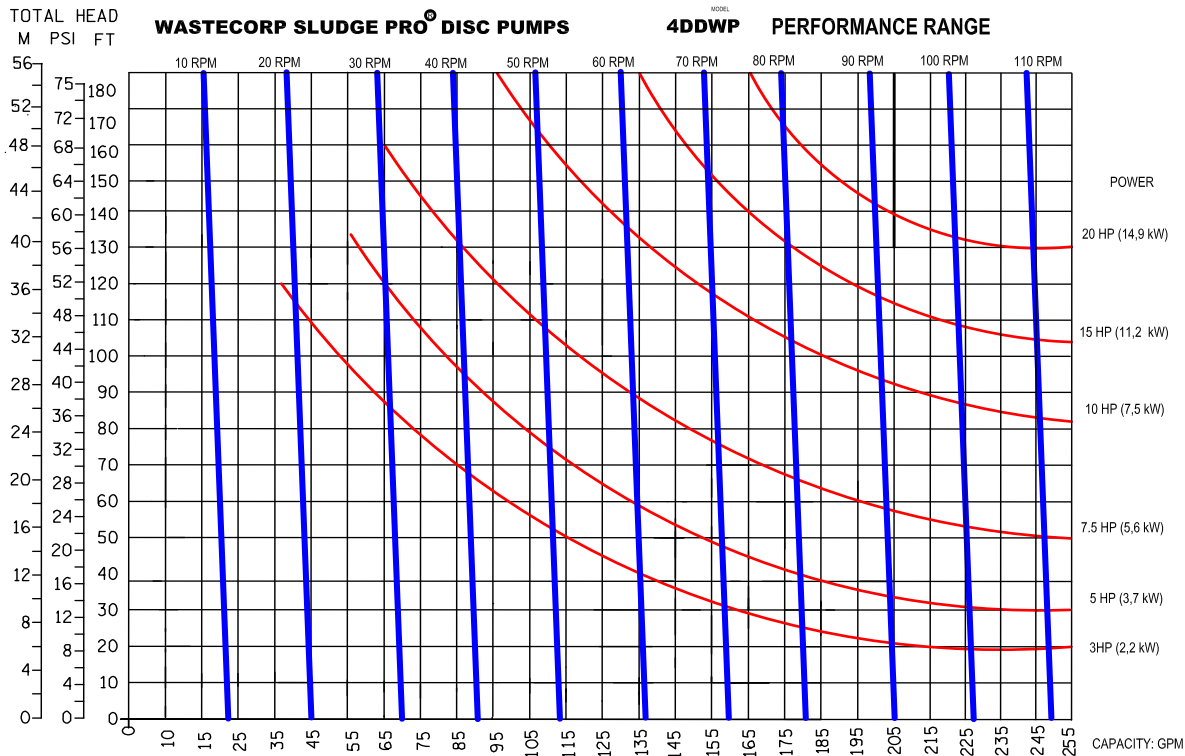

ISO ELEVATION VIEW

SUCTION LIFTS

Dry Prime Static Suction Lift: 25' (7.62m)
Wet Prime: 25" Hg 28.4' (8.6m)

CURVE NO.: 63911-00 MODEL: 4DDWP

SIZE: 4" x 4" RPM: VARIOUS

SP. GR.: 1.0 @ 68°F

Displacement Per Stroke: 2.28 Gal/Revolution



Wastecorp Pumps USA
P.O. Box 70
Grand Island, New York 14072 | USA
Tel: 888.829.2783
sales@wastecorp.com
www.wastecorp.com

Wastecorp Pumps Inc.
50 Shorncliffe Road
Toronto, Ontario M8Z-5K1 | Canada
Tel: 416.233.3000
info@wastecorp.com

Wastecorp Pumps International
345 W. 85th Street
New York, New York 10024 | USA
Tel: 201.445.2882
qt@wastecorp.com