

**MUD SUCKER®**  
DIAPHRAGM PUMPS

# FAC-DD™ Series

Electric  
Double Diaphragm  
Pumps

4FAC-EC-DD™

## FEATURES

Pump up to 300 GPM

Runs dry without damage

Positive displacement pump

Transfer solids up to 2½" or  
50% by volume

Cast iron pump body

13" diaphragms (x2)

High performance EPDM  
flapper valves (clack)



**WASTECORP.**  
Pumps®

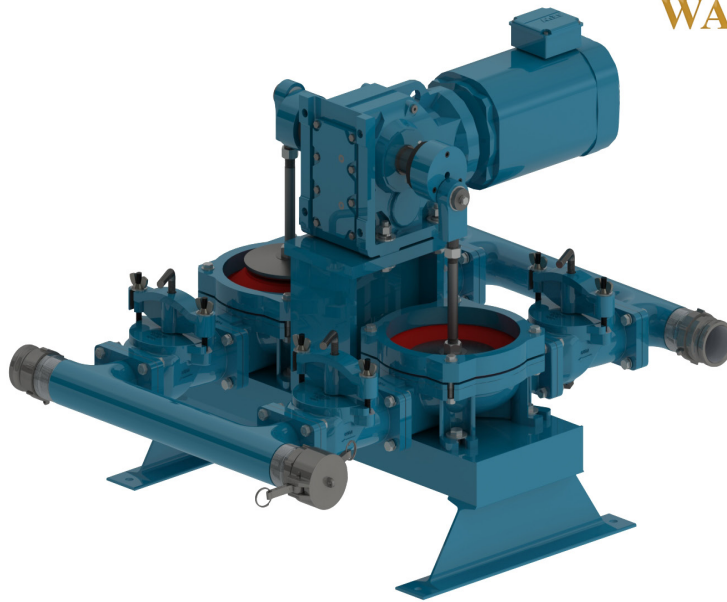

## ELECTRIC DOUBLE DIAPHRAGM PUMPS WITH NEW FLAPPERS FOR EASY ACCESS.

Wastecorp's latest electric double diaphragm pump, the Mud Sucker® 4FAC-EC-DD™ is an advanced technology pump to help you pump the tough stuff. With a redesigned flapper valve system, you can access the suction and discharge internals with the twist of a handle. In seconds you can inspect the area, change the flappers quickly and get back to business.

Select from single, three phase and explosion proof drive options to get the right pump for your application. With the widest selection of accessories and custom configurations you get the exact pump out you're looking for without long lead times.

### Electric Double Diaphragm Pumps With Advanced Flapper Technology

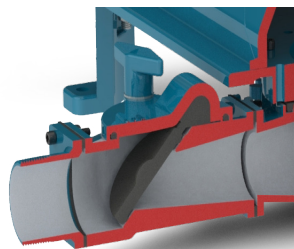

#### Easy Flapper Access

Access the suction and discharge in seconds. With the twist of a handle you can inspect the suction and discharge or replace flappers.

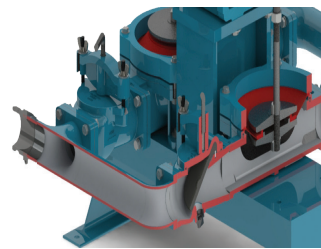

#### Heavy Duty Design

Make no mistake, all double diaphragm pumps are not alike. The Mud Sucker features a cast iron pump body with premium components.

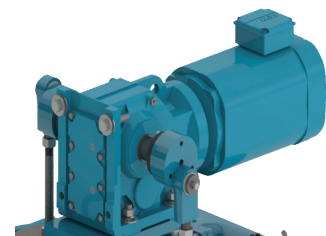

#### TOP Rated Drive Systems

Top rated drive systems available in single phase, three phase and explosion proof models.

### WHAT THIS MEANS TO YOU.

Heavy duty EPDM flappers help you pump the tough stuff like no other diaphragm pump.

Get long life cycles and improve your pumping productivity. Spare parts are affordable and are easy to change.

Enhanced performance with motors designed for your pump helps you take advantage of all the Mud Sucker pump can do for you

## Electric Double Diaphragm Pumps With Advanced Flapper Technology

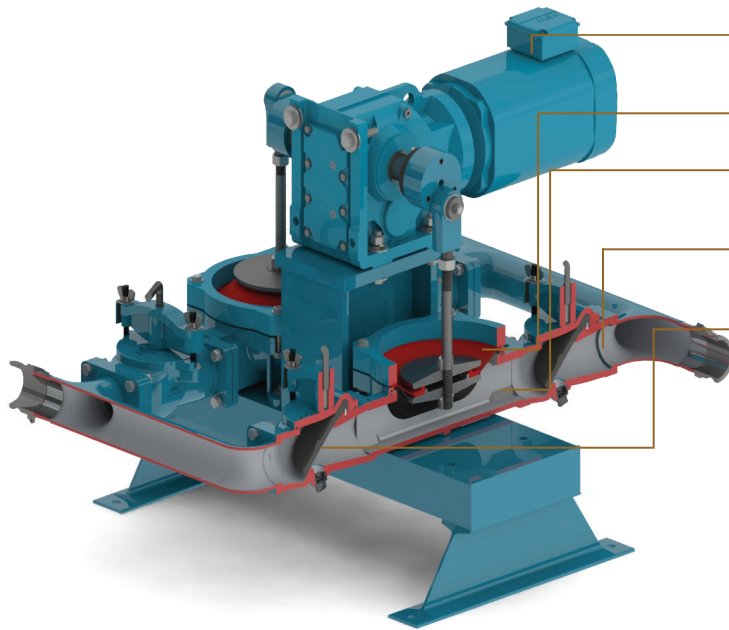

Premium Siemens®, SEW Eurodrive® or equivalent drive system

14¾" Santoprene® diaphragm

Exclusive Wastecorp engineered velocity channel to move fluids without clogging

Pump Internals available with industry specific components

**Access flappers in seconds with the exclusive Mud Sucker flapper valve system.**

Mud Sucker electric double diaphragm pumps are manufactured in North America. Country/region specific models are available worldwide.

### Performance Range

|                     |                                 |
|---------------------|---------------------------------|
| Max. capacity*      | 300 GPM                         |
| Max. Suction lift   | 25' vertical or 75' horizontal  |
| Max. discharge head | 50' vertical or 300' horizontal |
| Solids handling     | 2.5" dia or 50% by volume       |

### Pump Specifications

|                                      |                                      |
|--------------------------------------|--------------------------------------|
| Suction inlet/outlet size            | 4"x4"                                |
| Max. liquid temperature              | 140°F (60°C) continuous              |
| Pump body casing                     | Cast iron                            |
| Diaphragm                            | 14¾" dia TPE Santoprene® Severe duty |
| Flapper valves                       | EPDM                                 |
| Gearbox/Motor                        | SEW Eurodrive/Siemens                |
| Ultimate radial static load capacity | 9,000 Lbs                            |

### Motor Specifications

| Description                          | Part No. | Motor Option                           |
|--------------------------------------|----------|--|
| Standard motor, Three phase (TEFC)   | 64995-00 | 7.5 HP/1800RPM/3/60/230-460V           |
| Single Phase (TEFC)                  | 64995-10 | 7.5 HP/1800RPM/1/60/115-230V           |
| Explosion Proof (Three phase, TEXP)  | 64995-60 | 7.5 HP/1800RPM/3/60/230-460V (or 575V) |
| Explosion Proof (Single phase), TEXP | 64995-70 | 5 HP/1800RPM/1/60/115-230V TEXP        |

### Dimensional Drawing

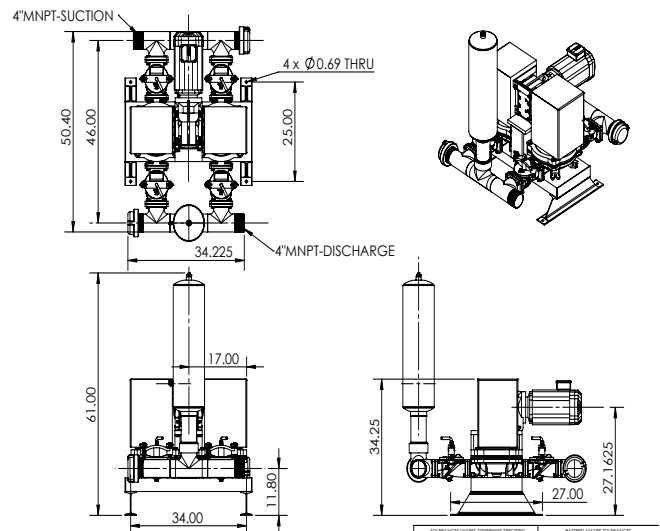

### Performance Curve

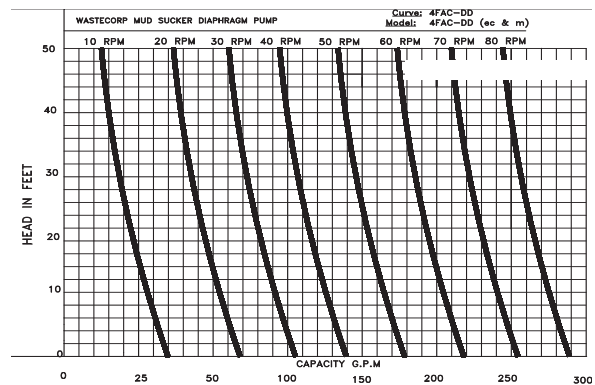

## Mud Sucker® Diaphragm Pumps

Toll-Free: 1.888.829.2783 Email: [info@wastecorp.com](mailto:info@wastecorp.com)

Website: <http://www.wastecorp.com>

  
**WASTECORP.**  
**Pumps®**  
OEM Manufacturer