

**SLUDGE PRO®**  
DISC PUMPS  
**4SDWP-SS™**

**BENEFITS**

TRANSFER FROM  
0-127 GPM

MAX. HEAD TO 184'  
(80 PSI)

NO REGULAR  
MAINTENANCE  
REQUIRED

TWO YEAR LIMITED  
WARRANTY\*

IDEAL FOR ABRASIVE,  
VISCOUS AND SHEAR  
SENSITIVE MEDIA

RUNS DRY = NO DAMAGE

SELF PRIMING PUMP

HIGHER OPERATING  
PRESSURE

NEXT GENERATION DISC  
PUMP TECHNOLOGY

\*Contact factory for warranty details.



Patent Pending

**LOWER RPM SPEEDS = LESS WEAR.**  
**JUST PART OF THE SLUDGE PRO DIFFERENCE.**

Sludge Pro® disc pumps operate at lower RPM speeds than comparable double disc type pumps. This allows for enhanced component life and less maintenance down the road. Sludge Pro's are designed for a wide range of slurry and sludge process applications for the municipal, industrial, chemical and food processing industries. These durable leak-free pumps are self priming and can run dry without damage for uncompromising pumping reliability. Select from standard direct drive, belt driven, air, hydraulic and engine driven systems.

**SLUDGE PRO® 4SDWP - DISC PUMPS**



**Advanced Disc Pump Technology**

- Seal-less, glandless & leak free design
- OSHA compliant Guard
- Over six models to select from



**Innovative Trunnion Options**

Not all pumping applications are alike, that's why Wastecorp offers you the right elastomer for your application including:

- Santoprene®
- Teflon®
- Buna-N®
- Nordel®
- Viton®
- Neoprene

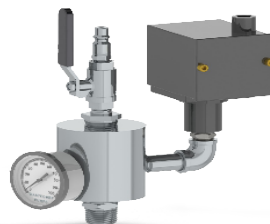

**Pressure Sensor Assembly**

Provides safe protection against dead heading, closed valves or other discharge blockages that can damage the pump. Also permits direct charging of pulsation dampener and access for cleaning.

### CUT AWAY

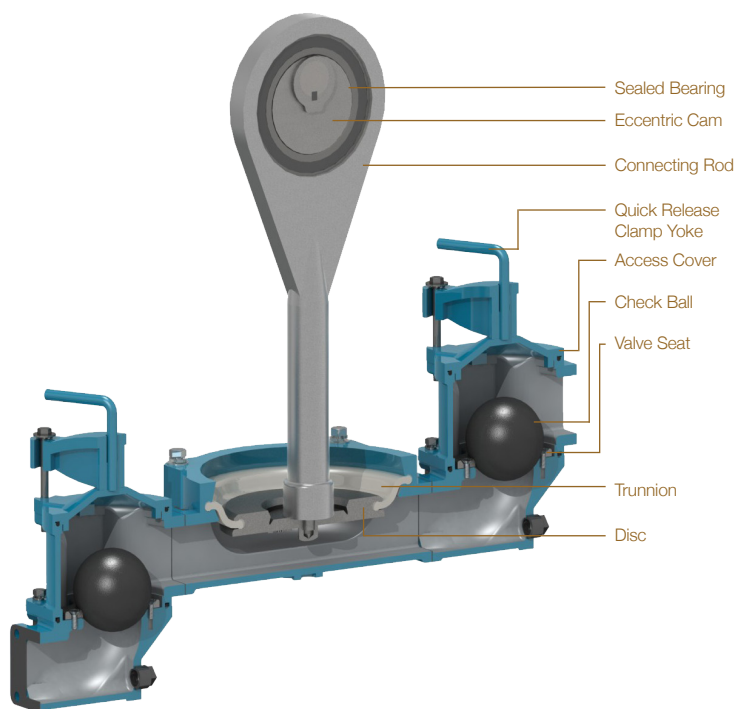

### TECHNICAL SPECIFICATIONS

<b>Model</b>	<b>Sludge Pro® 4SDWP</b>
<b>Connection Size</b>	4" 150# Flanged
<b>Typical Flow Range</b>	0-127 GPM
<b>Solids Handling</b>	Max 1¾"
<b>Displacement</b>	1.15 gal/rev
<b>Max. Suction Lift</b>	25'
<b>Max. Discharge Head</b>	184' (80 psi) (5.1 bar)
<b>Max. Liquid Temp.</b>	350°F (176°C)
<b>Operating Speed</b>	up to 110 RPM

### MATERIALS OF CONSTRUCTION

	<b>Standard</b>	<b>Optional</b>
<b>Trunnion</b>	<b>Neoprene</b> (TPE) 0°F to 200°F	<b>Santoprene</b> -40°F to +225°F <b>Buna-N®</b> +10°F to +180°F <b>Viton®</b> -40°F to +350°F <b>Teflon®</b> (PTFE) +40°F to +220°F <b>Nordel®</b> -60°F to +280°F
<b>Discs</b>	Ductile Iron, ASTM A 536, Grade 65-45-12	
<b>Ball Valve</b>	Urethane	Teflon®
<b>Sectionalized Construction</b>	Cast Iron ASTM A48 Class 30	See Coating Options Below
<b>Eccentric Cam</b>	Ductile iron ASTM A 536, Grade 65-45-12	
<b>Drive Shaft</b>	400 Series SS	
<b>Connecting Rod</b>	Ductile iron ASTM A 536, Grade 65-45-12	
<b>Base Frame</b>	Heavy Duty Fabricated Steel	304SS, Galvanized Steel, 316 SS

### DRIVE SYSTEM OPTIONS

<b>Direct Dive</b>	Electric Motor
<b>Optional</b>	Air, hydraulic, belt driven
<b>Engine Driven</b>	Gas or diesel

Note: Consult factory for applications exceeding maximum pressure and/or temperature indicated.

### WETTED CASTING COATING OPTIONS

Xylan, ETFE / PTFE, Dura-S, Nitrile, Neoprene, Nordel, Viton, Hypalon

**APPROXIMATE PUMP DIMENSIONS**

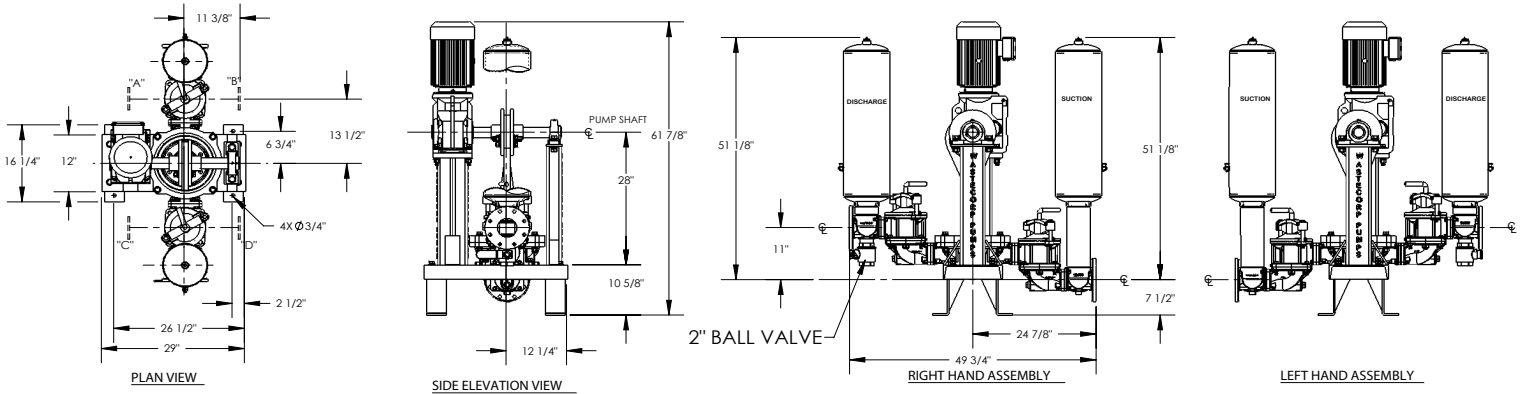

**PUMP CURVE**

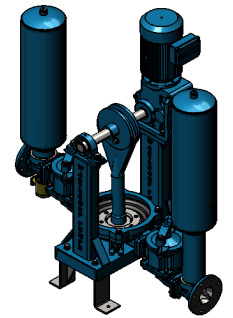
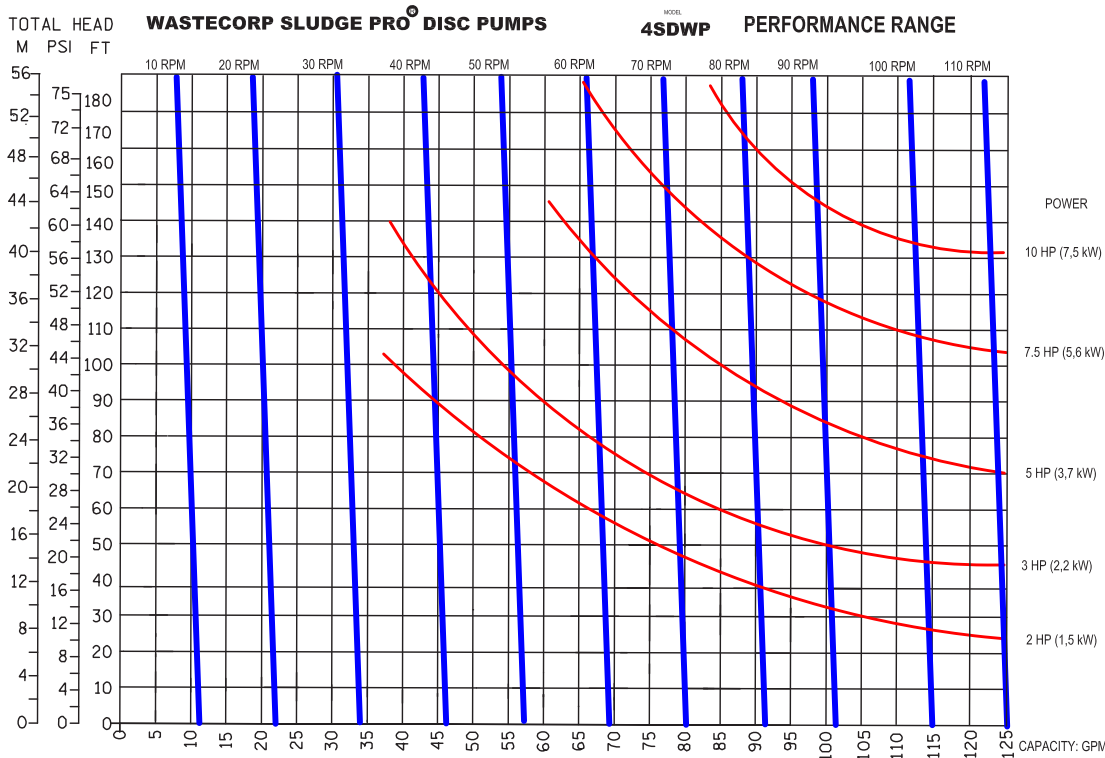

ISO ELEVATION VIEW

**SUCTION LIFTS**

Dry Prime Static Suction Lift: 25' (7.62m)  
 Wet Prime: 25" Hg 28.4' (8.6m)

CURVE NO.: 63910-00 MODEL: 4SDWP

SIZE: 4" x 4" RPM: VARIOUS

SP. GR.: 1.0 @ 68°F

Displacement Per Stroke : 1.15 Gal/Revolution