

**Mud Sucker®  
Diaphragm Pumps  
B Series**

**Solids Handling  
Diaphragm Pumps**

4B-M™  
Standard Piping  
Engine Driven

**FEATURES**

- 4" Connection size
- .....
- Pump up to 110 GPM
- .....
- Transfer spherical solids up to 2¼" or 50% by volume
- .....
- Pump up to 50' vertical or 300' horizontal
- .....
- 14¾" heavy duty diaphragm
- .....
- Multiple drive options and industry specific components

**PROFESSIONAL**



Pump shown with optional wheel kit package

**Performance Range**

<b>Max. capacity</b>	110 GPM
<b>Max. suction lift</b>	25' vertical or 75' horizontal
<b>Max. discharge head</b>	50' vertical or 300' horizontal
<b>Solids handling</b>	2¼" dia or 50% by volume

**Pump and Motor Specifications**

<b>Suction inlet/outlet size</b>	4"x4"
<b>Max. liquid temperature</b>	104°F (40°C) continuous
<b>Pump body casing</b>	Cast iron (ASTM A356, Class 30)
<b>Diaphragm</b>	14¾" dia thermoplastic elastomer (red) Severe duty -25°F to 212°F Optional: Neoprene
<b>Ball valves</b>	5-1/8" diameter polyurethane with steel core
<b>Gearbox</b>	Helical bevel cast iron housing with heat treated gears
<b>Hardware</b>	Zinc plated
<b>Rod end bearing body</b>	Cast iron, protective coated for corrosion resistance
<b>Ball bearing</b>	Cast iron, protective coating for corrosion resistance
<b>Ultimate radial static load capacity</b>	9,000 Lbs

**Motor Options**

<b>Description</b>	<b>Part No.</b>	<b>Motor Option</b>
Gas Engine	61727-00	9 hp, Honda GX270
Diesel Engine	61727-10	6.5 hp, Kohler/Yanmar

# Mud Sucker® Diaphragm Pumps 4B Series

Professional Solids Handling Diaphragm Pumps

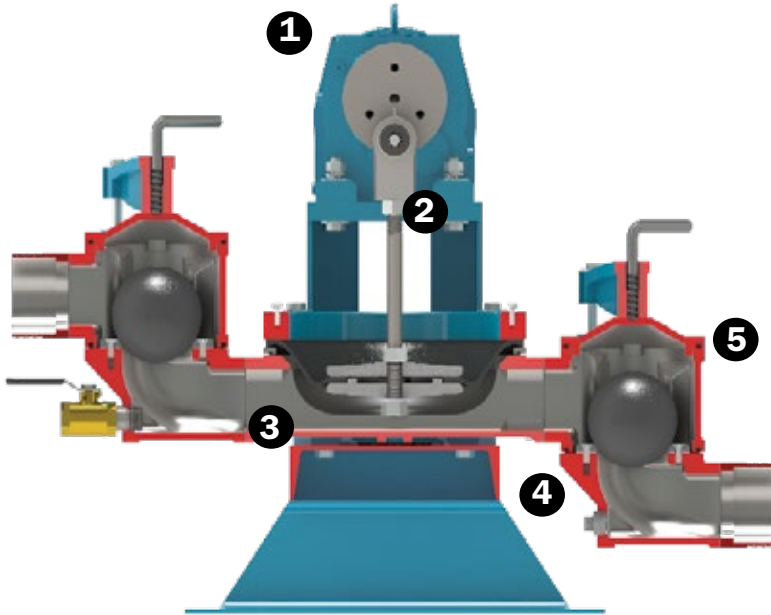

- 1** Premium drive systems form the industry's top rated manufacturers.
- 2** Heavy duty crank arm designed to pump the tough stuff at 110 GPM (max).
- 3** Exclusive Wastecorp engineered contoured velocity channel to move fluids without clogging.
- 4** Heavy duty cast iron pump body for unmatched durability.
- 5** Valve chambers crush solids and make slurries easier to pump.

## Professional Options for Professional Applications



Wastewater Containment System



4B Series - Trolley Mounted



4B Series - Trailer Mounted



4B Series - Dolly Mounted



4B Series - In-line Configuration

## Mud Sucker® Diaphragm Pumps

Toll-Free North America  
1.888.829.2783

Worldwide  
201.445.2882













Website  
<http://www.wastecorp.com>

E-mail  
[info@wastecorp.com](mailto:info@wastecorp.com)

  
**WASTECORP**  
**Pumps®**  
OEM Manufacturer



# ACCESSORIES

Part no.	Description	Part no.	Description
 19022-00	<b>Recommended!</b> Pressure relief valve, bronze set at 40 psi	 61747-00	Utility trailer (non-DOT) w/2" ball hitch
 61740-00	Basic spare parts kit (diaphragm and flappers)	 61741-00	Comprehensive spare parts kit (diaphragm, flappers gaskets, weights and hardware)
 60728-00	Non-collapsible EPDM hose 2"x20'. Camlocks included	 Various	Wet section coatings for specific applications
 51333-10	Discharge hose, lay flat (brown) 2"x50'. Camlocks included	 60469-00	Camlock fitting 4" alum. male adapter MNPT
 34383-00	Stainer, sq. hole (solids) 2" FNPT	 60506-00	The Gulper™ Suction tool No more bending
 61387-00	Universal sewer adapter assembly	 61537-00	Clear swing check valve 4" FPTxFPT