

**SLUDGE PRO®**  
**TRIPLEX DISC PUMPS**  
**6TDWP™**

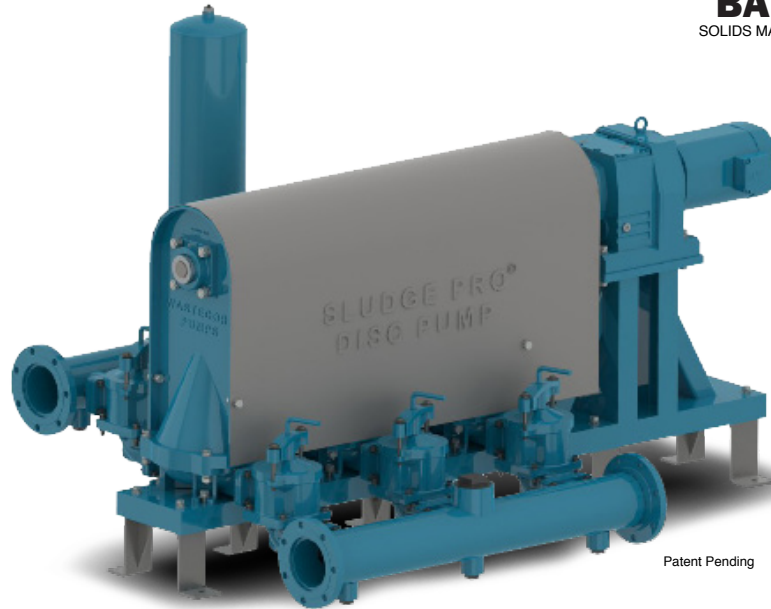

Patent Pending

**BENEFITS**

TRANSFER FROM  
0-375 GPM

MAX. HEAD TO 184'  
(80 PSI)

NO REGULAR  
MAINTENANCE  
REQUIRED

TWO YEAR LIMITED  
WARRANTY\*

IDEAL FOR ABRASIVE,  
VISCOUS AND SHEAR  
SENSITIVE MEDIA

RUNS DRY = NO DAMAGE

SELF PRIMING PUMP

HIGHER OPERATING  
PRESSURE

NEXT GENERATION DISC  
PUMP TECHNOLOGY

\*Contact factory for warranty details.

**TAKING HIGHER CAPACITY DISC PUMP  
TECHNOLOGY TO THE NEXT LEVEL.**

Sludge Pro® disc pumps are designed for a wide range of slurry and sludge process applications for the municipal, industrial, chemical and food processing industries. These durable leak-free pumps are self priming and can run dry without damage for uncompromising pumping reliability. Select from standard direct drive, belt driven, air, hydraulic and engine drive systems.

**SLUDGE PRO® 6TDWP - TRIPLEX DISC PUMPS**

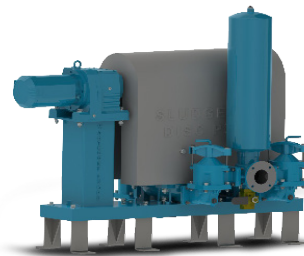

**Advanced Disc Pump Technology**

- Seal-less, glandless & leak free design
- OSHA compliant guard
- Over six models to select from



**Innovative Trunnion Options**

Not all pumping applications are alike, that's why Wastecorp offers you the right elastomer for your application including:

- Santoprene®
- Teflon®
- Buna-N®
- Nordel®
- Viton®
- Neoprene

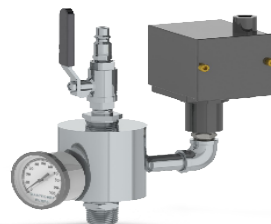

**Pressure Sensor Assembly**

Provides safe protection against dead heading, closed valves or other discharge blockages that can damage the pump. Also permits direct charging of pulsation dampener and access for cleaning.

## CUT AWAY

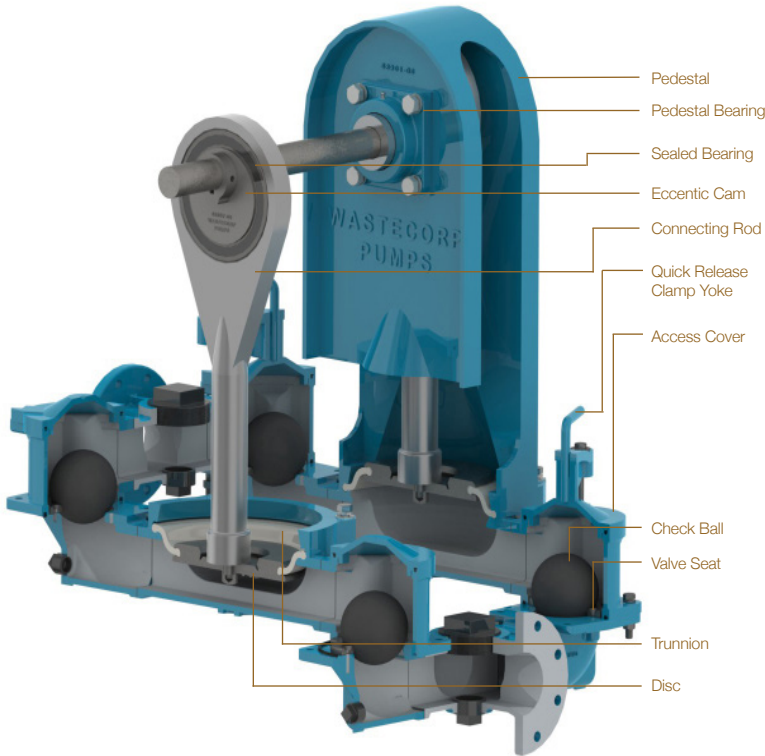

## APPROXIMATE PUMP DIMENSIONS

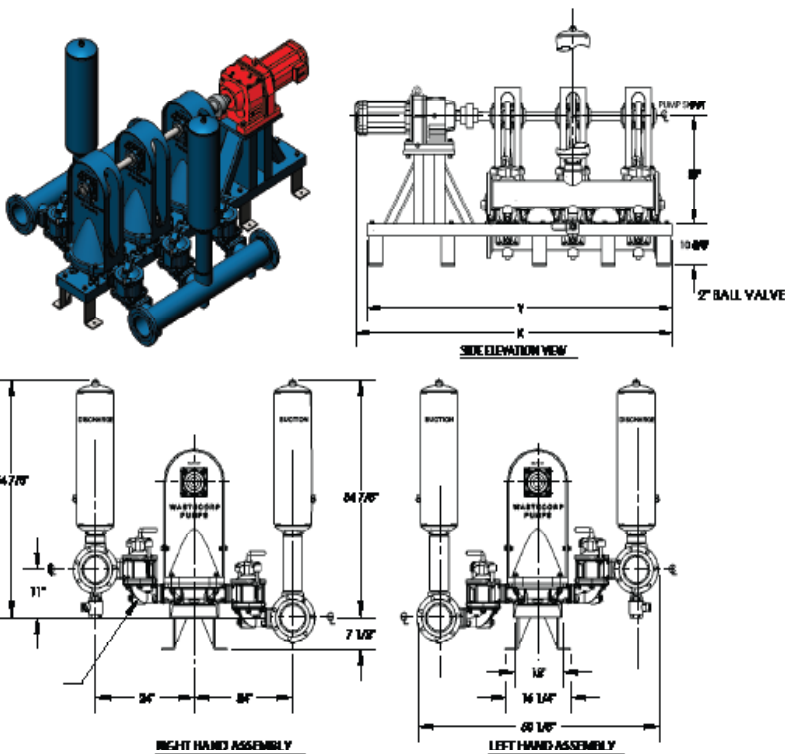

## TECHNICAL SPECIFICATIONS

<b>Model</b>	<b>Sludge Pro® 6TDWP</b>
<b>Connection Size</b>	6" 150# Flanged
<b>Typical Flow Range</b>	0-375 GPM
<b>Solids Handling</b>	Max 1¾"
<b>Displacement</b>	3.46 gal/rev
<b>Max. Suction Lift</b>	25'
<b>Max. Discharge Head</b>	184' (80 psi) (5.1 bar)
<b>Max. Liquid Temp.</b>	350°F (176°C)
<b>Operating Speed</b>	up to 110 RPM

## MATERIALS OF CONSTRUCTION

	<b>Standard</b>	<b>Optional</b>
<b>Trunnion</b>	Neoprene (TPE) 0°F to 200°F	Santoprene -40°F to +225°F Buna-N® +10°F to +180°F Viton® -40°F to +350°F Teflon® (PTFE) +40°F to +220°F Nordel® -60°F to +280°F
<b>Discs</b>	Ductile Iron, ASTM A 536, Grade 65-45-12	
<b>Ball Valve</b>	Urethane	Teflon®
<b>Sectionalized Construction</b>	Cast Iron ASTM A48 Class 30	See Coating Options Below
<b>Pedestal</b>	Ductile iron ASTM A 536, Grade 65-45-12	
<b>Eccentric Cam</b>	Ductile iron ASTM A 536, Grade 65-45-12	
<b>Drive Shaft</b>	400 Series SS	
<b>Connecting Rod</b>	Ductile iron ASTM A 536, Grade 65-45-12	
<b>Base Frame</b>	Heavy Duty Fabricated Steel	304SS, Galvanized Steel, 316 SS

## DRIVE SYSTEM OPTIONS

<b>Direct Dive</b>	Electric Motor
<b>Optional</b>	Air, hydraulic, belt driven
<b>Engine Driven</b>	Gas or diesel

Note: Consult factory for applications exceeding maximum pressure and/or temperature indicated.

## WETTED CASTING COATING OPTIONS

Xylan, ETFE / PTFE, Dura-S, Nitrile, Neoprene, Nordel, Viton, Hypalon

# PUMP CURVE

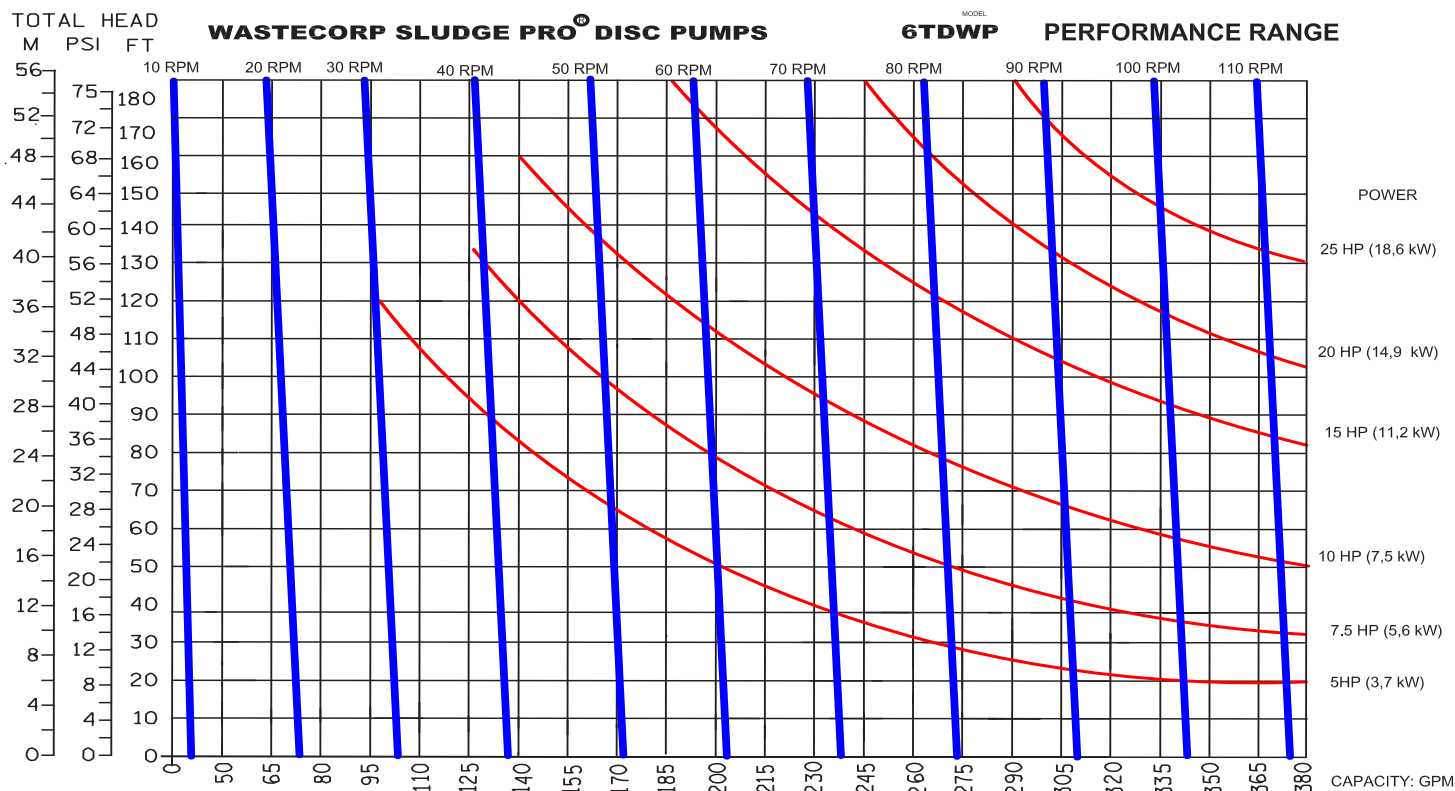

### SUCTION LIFTS

Dry Prime Static Suction Lift: 25' (7.62m)

Wet Prime: 25" Hg 28.4' (8.6m)

CURVE NO.: 64171-00 MODEL: 6TDWP

PIPE SIZE: 6" x 6" RPM: VARIOUS

SP. GR.: 1.0 @ 68°F Displacement: 3.46 Gal/Revolution

Sludge Pro® and Wastecorp® are registered trademarks of Wastecorp (WPCI). Specifications and illustrations are subject to revision without notice. Wastecorp is not liable for any incompleteness or inaccuracies. Wastecorp is not liable for any consequential, incidental or indirect damages relating to these specifications or their use.

Curve based on water (specific gravity = 1.0), with 10 foot static lift. The performance curve shown were taken from actual tests of standard production pumps, and reflect an average performance of the pump indicated.

REV. DS 4/2015