



HEAVY DUTY PERFORMANCE WITHOUT COMPROMISE.

With the Trash Flow TFCC-4 Series, you get a powerful 4" self priming centrifugal trash pump with fluid handling capabilities up to 740 GPM and max head up to 115 ft. Never compromise on quality. Go with a Trash Flow.

FEATURES

TRANSFER UP TO
740 GPM (104m³)

MAX. HEAD 115 FT
(168m³)

ADJUSTABLE &
SHIMLESS IMPELLER
CLEARANCE

HEAVY DUTY BEARINGS
AND CASTINGS

EASILY REMOVABLE
ROTATING ASSEMBLY

FULL IMPELLER ACCESS

SOLIDS HANDLING
IMPELLER

QUICK SELF PRIMING
CAPABILITIES

DOUBLE FLOATING
MECHANICAL SEAL

DUAL LIP SEAL BEARING
PROTECTION*

*optional

TRASH FLOW® CONFIGURATIONS

FLEX COUPLED



BELT DRIVE VERTICAL



BELT DRIVE PIGGY BACK

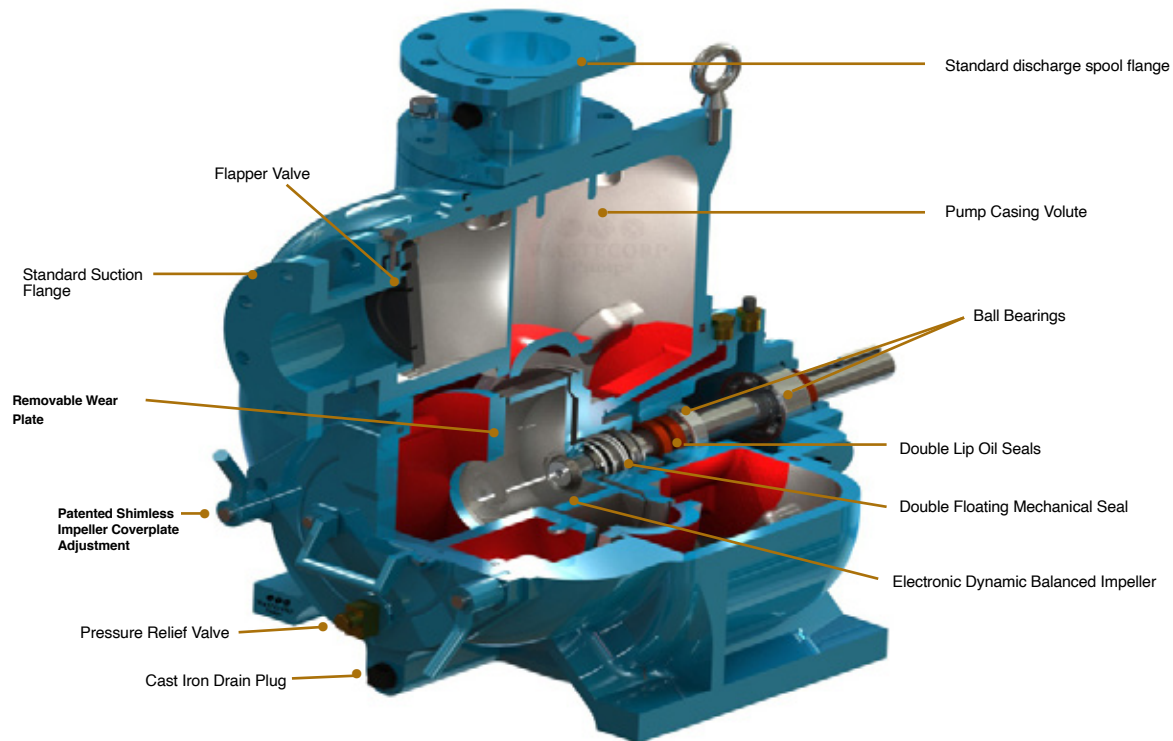

TRASH FLOW®

SELF PRIMING TRASH PUMPS

TFCC-4™

4"x4"



WASTECORP.
Pumps®

FEATURES



REMOVABLE ROTATING ASSEMBLY

Experience less downtime and maintenance hassles with the Trash Flow's removable rotating assembly. The pump volute and piping are not disturbed during maintenance.

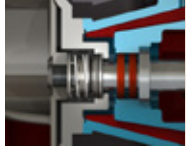

DOUBLE FLOATING MECHANICAL SEAL

Wastecorp's mechanical seals are designed for the harsh pumping conditions in today's municipal and industrial solids handling jobs.



SOLIDS HANDLING IMPELLERS

Trash Flow pumps feature our standard premium two-vane solids handling impellers with solids handling capabilities up to 3" (75mm).



OPTIONAL SUCTION AND DISCHARGE GAUGES

Monitor operating pressure easily with Wastecorp's optional suction and discharge gauges.

OPTIONAL CONFIGURATIONS



SEWAGE LIFT STATIONS

Let our pump designers engineer the ultimate lift station for your facility. We offer complete packaged solutions including control panels, valves and more.



TRAILER OR SKID MOUNT ENGINE

With our trailer or skid mounted diesel engine trash pumps, you'll get a DOT approved solutions for mobile wastewater transfer

Pump Size	4" x 4" [100 mm x 100 mm] ANSI/DIN
Pump Casing	Cast Iron Class 30
Operating Pressure	Maximum 86 psi (593 kPa)
Impeller	Open type, two vane. Material: Ductile Iron Pumps 3" (76,2 mm) spherical solids
Impeller Shaft	ANSI 4140 HT
Wear Plate, Replaceable	Hardened Steel
Cover Plate	Removable/Adjustable Cast Iron Class 30
Flapper Valve	Neoprene with steel reinforcing ring
Bearing Housing	Cast Iron
Seal Plate	Cast Iron
Shaft Sleeve	ANSI 17-4PH SST
Radial Bearing	Open single ball
Thrust Bearing	Open double ball
Bearing/Seal Cavity Lubrication	SAE No. 30 oil
Flanges	125# Ductile Iron ANSI or DIN
Gaskets	Buna-N, compressed synthetic fibers, vegetable fiber, PTFE, cork, and rubber
O-Rings	Buna-N Teflon coated
Hardware	Plated steel/grade 8/SST
Pressure Release Valve	Brass
Oil Level Sight Gauges	Bearing and Seal Cavity
Net Weight	625 lbs/283KG
Optional Equipment and Materials:	Stainless Steel. Automatic air release valve, 120V/240V casing heater. High pump temperature shutdown kit, moisture probe, gauge kit, NPT & DIN standard suction and discharge flanges. Other elastomers available.

Seal Specifications:	Mechanical oil-lubricated, double floating, self-aligning seal. Titanium & Tungsten Carbide rotating and stationary faces. Stainless steel metal components. Maximum temperature of liquid pumped 180°F/83°C.
-----------------------------	---

Note: Consult factory for applications exceeding maximum pressure and/or temperature indicated.

BARE PUMP DIMENSIONS

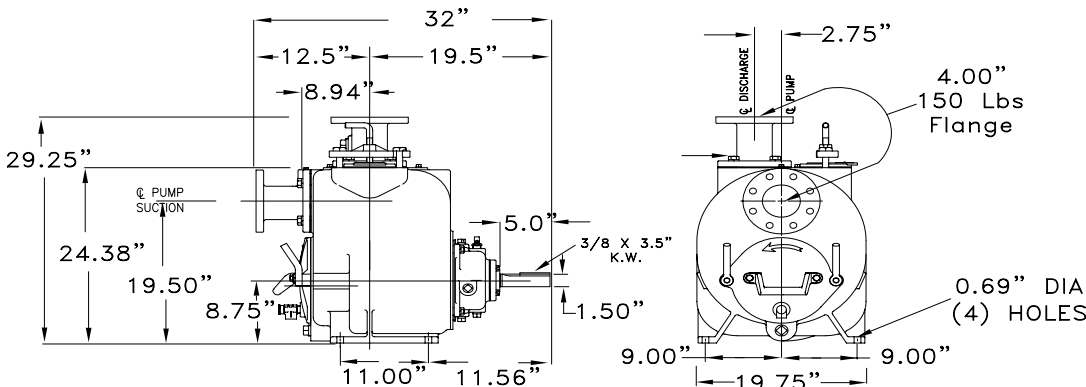

Dimensions and weight are approximate. Wastecorp Pumps reserves the right to make changes in design, materials and operating ranges without notice.

TRASH FLOW®
SELF PRIMING TRASH PUMPS

TFCC-4™

4"x4"



WASTECORP.
Pumps®

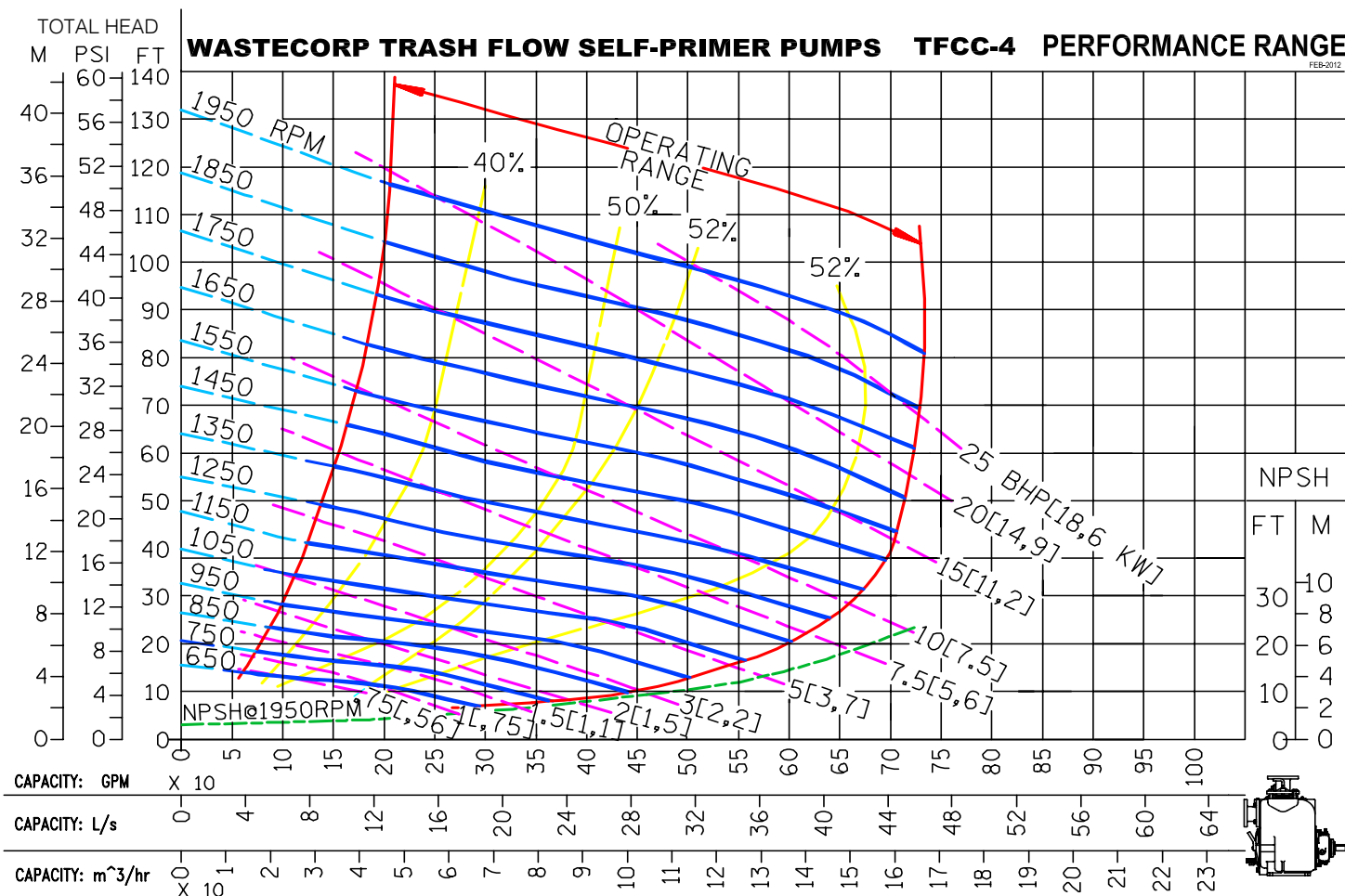

REPRIMING LIFTS

PUMP SPEED	PUMP SPEED	PUMP SPEED	PUMP SPEED	PUMP SPEED	PUMP SPEED
650 RPM	5 Ft.	1250 RPM	25 Ft.	1850 RPM	25 Ft.
750 RPM	8 Ft.	1350 RPM	25 Ft.	1950 RPM	25 Ft.
850 RPM	16 Ft.	1450 RPM	25 Ft.		
950 RPM	19 Ft.	1550 RPM	25 Ft.		
1050 RPM	22 Ft.	1650 RPM	25 Ft.		
1150 RPM	24 Ft.	1750 RPM	25 Ft.		

Determine NPSHr prior to using repriming table. Do not use as available suction lifts.

$$BHP = \frac{GPM \times FT \times SG}{3960 \times Efficiency}$$

$$KW = \frac{M^3 / HR \times M \times SG}{367 \times Efficiency}$$

Suction lift is limited by the available NPSH which is the corrected atmospheric pressure minus the dynamic suction lift, vapor pressure loss and 2 foot safety factor.



WASTECORP.
Pumps®

www.wastecorp.com

CURVE NO.: 62919-00 **MODEL:** TFCC-4

SIZE: 4" x 4" **IMPELLER DIA:** 9.75"

RPM: VARIOUS **SP. GR.:** 1.0 @ 68°F

Factory certified tests are performed using Hydraulic Institute acceptance Level B.

The performance curve shown were taken from actual tests of standard production pumps, and reflect an average performance of the pumps indicated. Wastecorp reserves the right to make changes in design, materials and operating ranges without notice.

WASTECORP
Pumps®
WASTECORP.COM

Wastecorp Pumps USA
P.O. Box 70
Grand Island, New York 14072 | USA
Tel: 888.829.2783 | Fax: 888.883.3320
sales@wastecorp.com

Wastecorp Pumps Canada Inc.
50 Shorncliffe Road
Toronto, Ontario M8Z-5K1 | Canada
Tel: 416.233.3000 | Fax: 416.233.2300
info@wastecorp.com

Wastecorp Pumps International
P.O. Box 70
Grand Island, New York 14072 | USA
Tel: 201.445.2882 | Fax: 201.445.3252
info@wastecorp.com