



Trash Flow® Dry Prime Pumps

## TFV4-M™ Series

Automatic Self-Priming  
Dry Prime Venturi Technology

### FEATURES

UP TO 1700 GPM  
PUMPING CAPABILITIES

UP TO 3" SOLIDS  
HANDLING CAPABILITIES

4" ANSI CONNECTIONS

UP TO 176° F FLUID  
TEMPERATURE

MAX. HEAD TO 150 FT.

MADE AND ASSEMBLED  
IN THE USA AND/OR  
CANADA

OPTIONAL ACCESSORIES

WASTECORP IS AN ISO  
9001, 14001 CERTIFIED  
DRY PRIME PUMP  
MANUFACTURER



## THE NEW STANDARD FOR DRY PRIME PUMPS MEET TRASH FLOW® TFV-4™ SERIES

Trash Flow Dry Prime pumps are built for emergency bypass and dewatering applications. The unique oil bath technology, ensures that the mechanical seal is always lubricated in its own chamber. This safeguard allows the pump to run dry indefinitely without damage. Trash Flow TFV Series pumps can pass 3" spherical solids and produce suction lifts to 28 Ft. This enhanced priming system, minimizes effluent discharge into the environment.

PROFESSIONAL DRY PRIME PUMPS - HIGH QUALITY. QUICK DELIVERY.



### VENTURI AIR EJECTOR PRIMING SYSTEM

Wastecorp's intelligent priming system, uses a Quincy compressor to rapidly evacuate air from the suction line which is exhausted to atmosphere. Liquid replaces the air, automatically priming the pump within seconds. The result is fast, efficient and environmentally friendly pump system.



### CUSTOMIZE YOUR TRASH FLOW DRY PRIME THE WAY YOU NEED IT.

With Wastecorp, you get a host of options to customize your dry prime pump the way you need it. Select from diesel, electric or natural gas motors, sound attenuated enclosures, trailer or skid mount, float regulator systems and much more. Wastecorp's dry prime specification is designed to meet or exceed any equivalent manufacturer.



### AVAILABLE HUSHER™ SERIES SOUND ATTENUATED HUT

For pumping in residential areas or where reduced noise is critical, Wastecorp offers the Trash Flow TVP Husher Series. This sound attenuated lockable enclosure reduces noise to 68 dBa @ 7 Meters which complies with most local regulations. A Wastecorp technical support representative can help you select the correct Husher for your application.

## Trash Flow® Dry Prime Pumps

### TFV4-M™ Series

Automatic Self-Priming  
Dry Prime Venturi Technology



3" solids handling impeller

Diesel, electric, or natural gas powered engines available

Instrument Panel includes oil pressure gauge, amp, hour and tachometer

Standard 80 gallon fuel tank

Simple maintenance

Trailer mounted or skid mounted models available

**Also available with Husher silent pumping package for pumping in residential areas.**

Manufactured in the United States and/or Canada. Wastecorp is an ISO 9001, 14001 certified dry prime pump manufacturer.

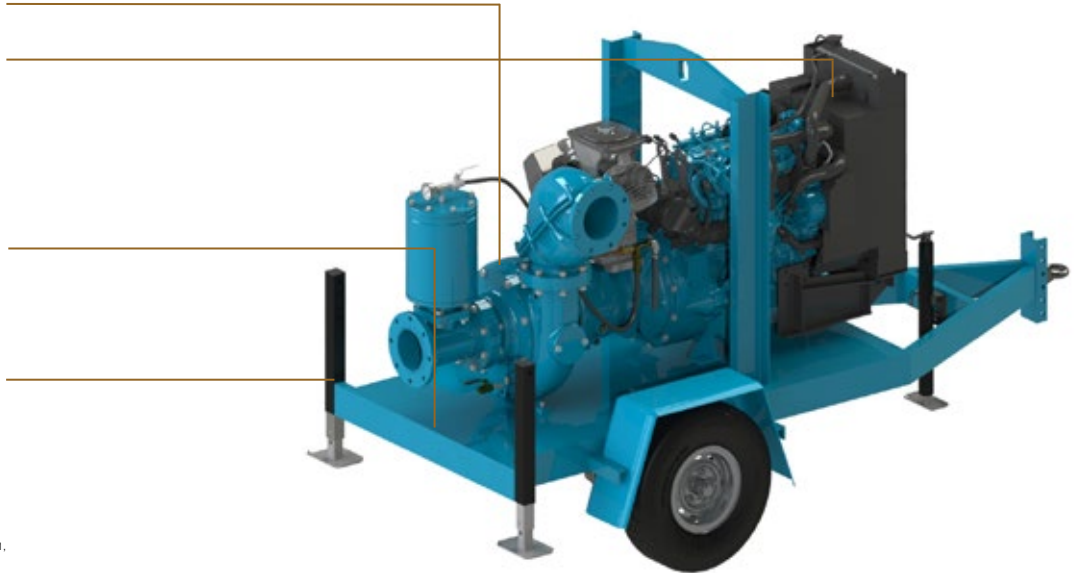

#### Available Options

- Auto-start for unattended 24 - hour operation (Lofa or murphy panel)
- Level regulator float system
- Highway trailer or skid mount
- Sound attenuated lockable enclosure (68 dBa @ 7 Meters)
- Diesel engine, electric motor or natural gas drive systems
- **Optional engines and hp available contact factory**

#### Pump Specifications

Suction connection	4" 150# ANSI B16.5
Discharge connection	4" 150# ANSI B16.5
Max capacity	1,700 GPM
Max solids handling	3.0"
Max Impeller Dia.	10"
Max temperature	176°F
Max head	150 ft.
Max operating speed	2000 rpm
Dry weight	2400 lbs

#### Engine Specifications

Certification	Final Tier 4 water cooled or interm air cooled
Fuel tank	80 gal standard (larger sizes available)
Instrument panel	Oil pressure gauge, amp, hour and tachometer
Fuel Consumption	2.4 gal/hr @2200 rpm / 2.0 gal/hr @1800 rpm

#### Materials of Construction

	Standard	Optional
Impeller	CA6NM SS	CD4MCu
Wear ring	Ductile Iron	316 SS
Shaft	17-4 PH	
Casing	Ductile Iron	CD4MCu
Bearing frame	Ductile Iron	CD4MCu
Mechanical seal	High Pressure liquid oil bath with high abrasion resistant solid carbon faces.	

## TFV4-M - Performance Curve

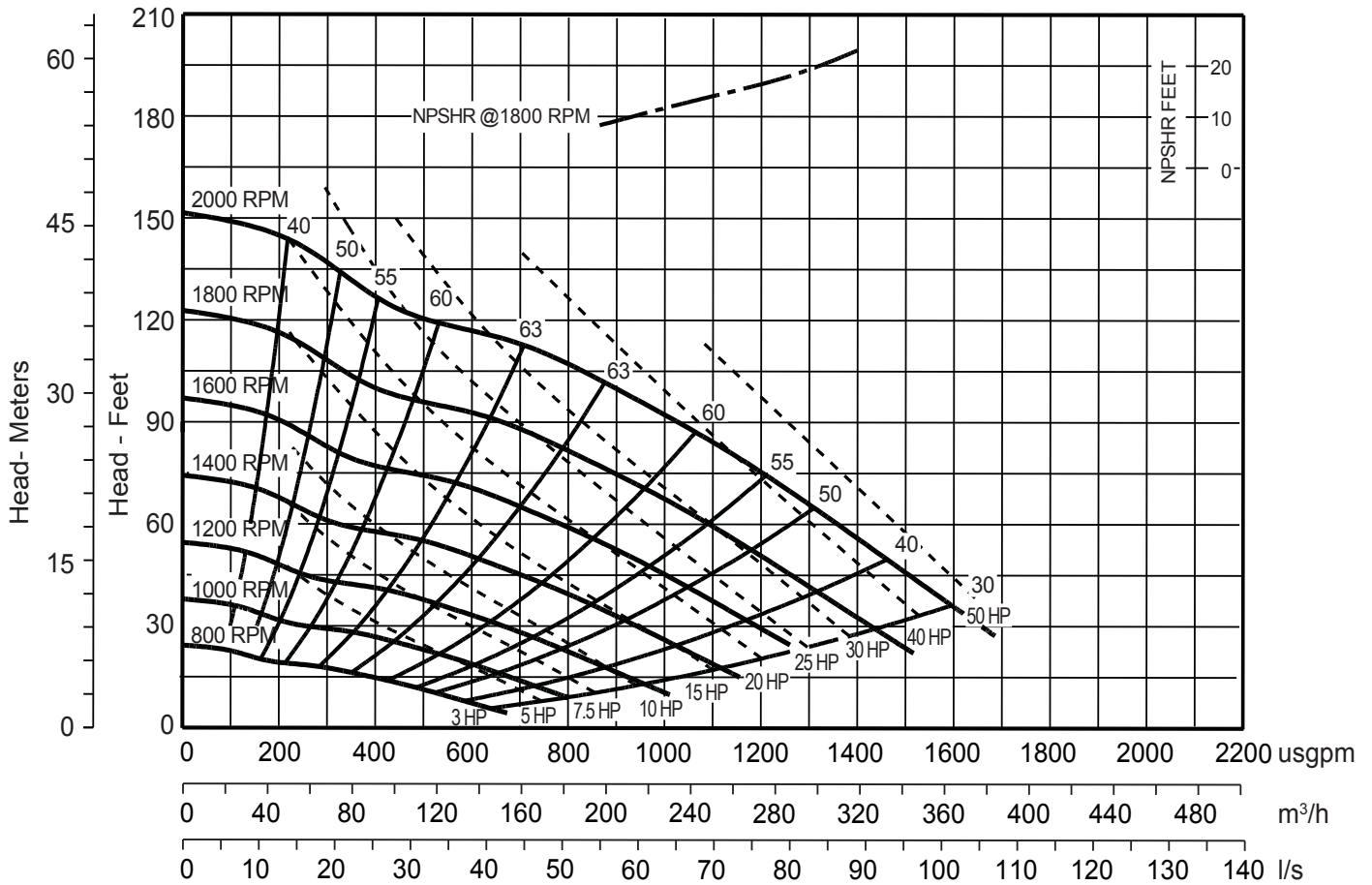

Optional engines and hp available contact factory.

Model	TFV-4	
Size	4" x 4"	115 mm x 115 mm
Impeller Diameter	10"	250 mm
Solids Handling Size	3.0"	75 mm