



**Sludge Sucker®**  
*Double*  
**Grout Pumps**

- 1 FA-GH-DD Series™
- 1.5 FA-GH-DD Series™
- 2FA-GH-DD Series™

**FEATURES**

SEVERE DUTY DESIGN FOR PROFESSIONAL GROUTING APPLICATIONS

YOUR CHOICE OF 1", 1.5" OR 2" CONNECTION

3.5 GALLON HOPPER FUNNEL

LIGHT WEIGHT MOBILITY SYSTEM

10' NON-COLLAPSIBLE HOSE WITH CAMLOCKS

GROUT INJECTOR WAND

**THE FLAWLESS PUMPING PERFORMANCE PROFESSIONALS EXPECT.**

Sludge Sucker® manual DOUBLE grout pump provide the ultimate in water based cementitious type grout pumping such as those made by Dayton®, Sika®, Five Star®, BASF Masterflow® and others. The Sludge Sucker features a completely redesigned crank mechanism to assist in pumping thicker grouts and select concrete based materials. Sludge Sucker® Grout pumps perform best when the grout ratio consistency is between fluid and flowable. \*Sludge Sucker® grout pumps are not recommended to transfer chemical based epoxy grouts.

**PROFESSIONAL GROUT PUMPS SYSTEMS FOR COMMERCIAL AND RESIDENTIAL APPLICATIONS**

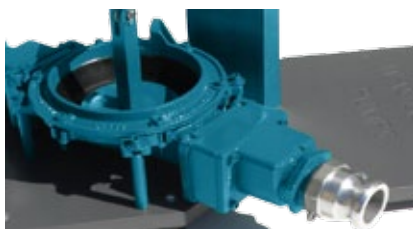

**SLUDGE SUCKER® DIAPHRAGM PUMP TECHNOLOGY.**

The Sludge Sucker is a severe duty design using the latest advances in diaphragm pump technology. Fluid flows more productively through the pump body making your job easier and quicker than ever before.

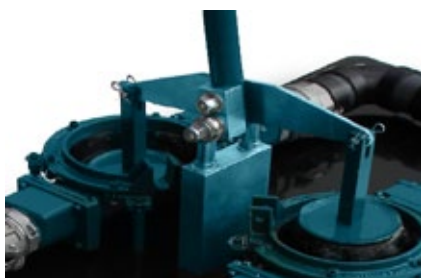

**COMPLETELY REDESIGNED CRANK ARM**

**NEW**

When you have thicker grouting jobs to finish, your manual grout pump better have a reinforced crank mechanism to withstand stroke after stroke of use. Wastecorp's new design extends the life of your grout pump up to 50% longer than comparable makes.



**SLICK HOPPER FUNNELS**

Our 3.5 gallon hopper funnel keeps you productive with up to 1.2 quarts of grout transferred per stroke. Plus, the bevelled rim reduces mess on your job site.

**APPROX. DIMENSIONS**

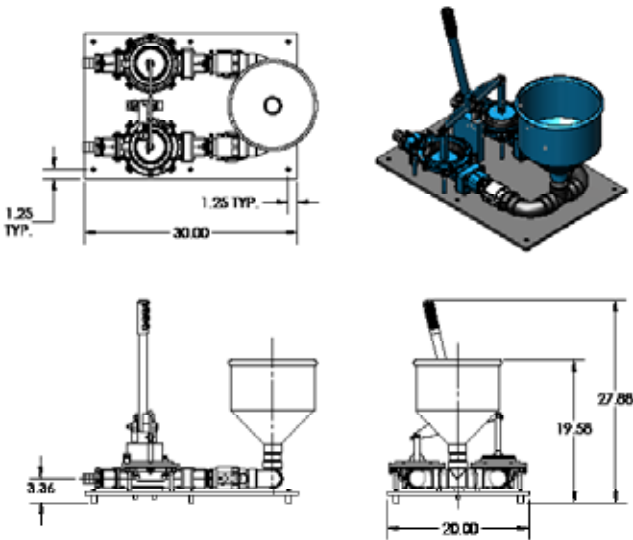

**Sludge Sucker® Performance Range**

**1", 1.5" or 2" Connection**

Max. capacity:	40 GPM *
Max Output Pressure:	0-20 psi
Max. Discharge head:	10' vertical/25' horizontal
Max. Solids handling:	1.5" dia or 50% by volume

**Sludge Sucker® Specifications**

**Double Grout Pump Series**

Part Number	63876-10 (1") 63876-15 (1.5") 63876-20 (2")
Max. liquid temperature	140° F (60° C) continuous
Pump body casing	Aluminum
Diaphragm	7" dia. fabric reinforced Buna-N
Flapper valves	Fabric reinforced Viton
Power source	Manual
Feed hopper capacity	3.5 gallons (.47 ft³)
Feed hopper material	Galvanized steel
Portable Base	High density polyethylene with anti-vibration feet
Connection	Aluminum male camlock
Inlet/outlet flanges	Aluminum
Hardware	Stainless steel

\* @ 2.4 quarts per stroke (based on water)

**OPTIONAL ACCESSORIES FOR SLUDGE SUCKER® GROUT PUMPS**



**SPARE PARTS KIT**  
P/N: 62754-00

Have parts ready when you need them. Order Genuine Wastecorp spare parts with your new Sludge Sucker.



**Grout Injector Hose**  
P/N: 62279-00

Non-collapsible green injector hose. 10' length standard. Professional duty.



**Grout Injector Wand**  
P/N: 62473-00

Make grouting tight or hard-to-reach areas a snap with our injector wand.

**SLUDGE SUCKER® MANUAL GROUT PUMPS**

Designed and Manufactured by Wastecorp Pumps in North America.

Toll-Free: 1.888.829.2783 Email: [info@wastecorp.com](mailto:info@wastecorp.com)

International: +1-201-445-2882