

TRASH FLOW®
ENGINE DRIVEN TRASH PUMPS
TFCC-12M™

FEATURES

TRANSFER UP TO 5500
GPM (1249 M³/HR)

MAX. HEAD 140 FT (42 M)

HEAVY DUTY BEARINGS
AND CASTINGS

EASILY REMOVABLE
ROTATING ASSEMBLY

VACUUM PRIME ASSIST
AVAILABLE*

“SILENT” PUMPING
MODEL AVAILABLE*

QUICK SELF PRIMING
CAPABILITIES

DOUBLE FLOATING
MECHANICAL SEAL

DUAL LIP SEAL BEARING
PROTECTION

*optional

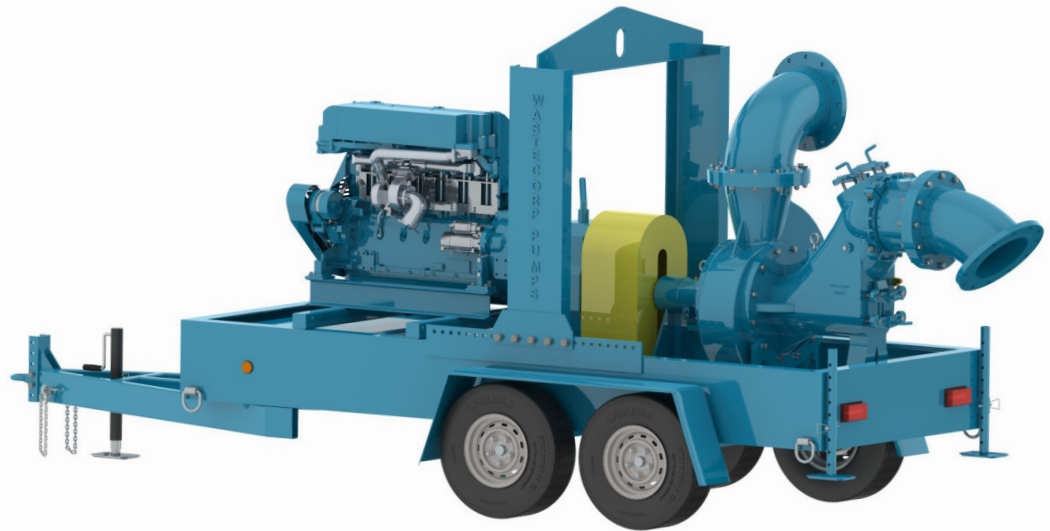

**DESIGNED FOR PUBLIC WORKS APPLICATIONS.
MAKES YOUR RESIDENTS HAPPIER.**

Trash Flow pumps for public works applications don't have it easy. They have to pump high volumes while providing operators with long life cycles and the durability to outlast the punishing conditions. That's exactly what you get with Wastecorp's Trash Flow TFCC-M-12. With up to 5500 GPM capabilities, flooded streets, water main breaks and backed up sewer get pumped out faster helping residents carry on with their day and improves productivity of your crew..

TRASH FLOW® TFCC-12M - OPTIONAL CONFIGURATIONS

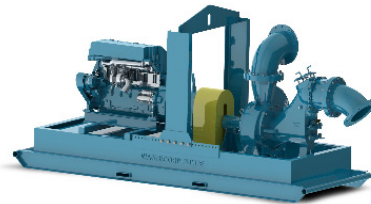

With or Without Wheels The TFCC-12 Moves Wastewater

The TFCC-12M is available as a skid mounted model complete with a heavy duty lifting bail to move around your job site. With a wide variety of diesel engine and control panel options available, you'll get exactly what you need for your job.

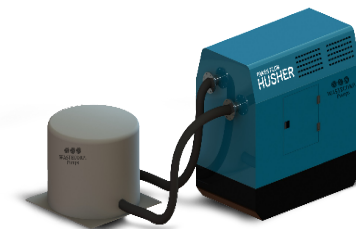

**Pumping in Residential Areas?
The Trash Flow Can Quiet Down**

One of the challenges when using a trash pump in residential areas is adhering to local noise regulations. Wastecorp's solution is the Trash Flow Husher with an acoustical hut to keep sound below 70 dBA.



**Intermittent Flow a Problem? “Vacuum Prime Assist” is
The Solution**

Vacuum prime assist is ideal when pumping fluid with large volumes of air or pulling through long suction lines. It is also environmentally friendly as there is no carryover of liquid into the environment because of the unique float box design.

TRASH FLOW®

ENGINE DRIVEN TRASH PUMPS

TFCC-12M™



FEATURES



REMOVABLE ROTATING ASSEMBLY

Experience less downtime and maintenance hassles with the Trash Flow's removable rotating assembly. The pump volute and piping are not disturbed during maintenance.

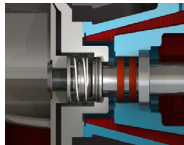

DOUBLE FLOATING MECHANICAL SEAL

Wastecorp's mechanical seals are designed for the harsh pumping conditions in today's municipal and industrial solids handling jobs.

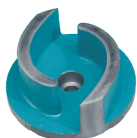

SOLIDS HANDLING IMPELLERS

Trash Flow pumps feature our standard premium two-vane solids handling impellers with solids handling capabilities up to 3" (75mm).



OPTIONAL SUCTION AND DISCHARGE GAUGES

Monitor operating pressure easily with Wastecorp's optional suction and discharge gauges.

OPTIONAL CONFIGURATIONS



SEWAGE LIFT STATIONS

Let our pump designers engineer the ultimate lift station for your facility. We offer complete packaged solutions including control panels, valves and more.

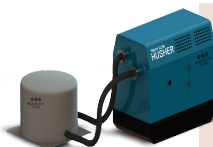

SOUND-ATTENUATED ENCLOSURES

When your application calls for an enclosure to reduce noise or provide added security, Wastecorp's Husher® models provide noise reduction below 70 dBA and lockable doors.

Model	Trash Flow® TFCC-12M
Connection Size	12" x 12" (300mm x 300mm)
Max. GPM	5500 GPM (1249 m³/hr)
Max. Suction Lift	16 ft.
Max. Discharge Head	61 psi (140 Ft 42 m)
Max. Liquid Temp.	160°F (71°C)
Pump Casing	Grey Iron, ASTM A48; Class 30
Operating Pressure	80 psi max. (551kPa)
Impeller	Max. 18" OD, Ductile Iron ASTM A536, Grade 60-40-18 (Impeller Trimming: If required) Semi-Open Type, Two-Vane Impeller, (two plane, computer dynamically balanced)
Max. Solids Handling	3" (76 mm)
Impeller Shaft	ANSI 4140 steel
Replaceable Wear Plate	SAE 1020 steel
Removable Cover Plate	Grey Iron, ASTM A48; Class 30
Flapper Valve	Neoprene with internal steel weight
Bearing Housing	Grey Iron, ASTM A48; Class 30 (includes oil sight glass and breather valve)
Seal Plate	Grey Iron, ASTM A48; Class 30
Shaft Sleeve	316 Stainless Steel
Radial/Thrust Bearing	NSK Open Ball
Bearing/Seal Cavity Lubrication	SAE No. 30 Non-Detergent Oil
Gaskets	Buna-N, Compressed Synthetic Fibers, PTFE, Vegetable Fiber, Cork and Rubber
Hardware	Standard Plated Steel, Brass Pressure Relief Valve, Bearing and Seal Cavity Oil Level Sight Gauges
Mechanical Seal	Double floating cartridge type, titanium tungsten-carbide rotating and stationary faces, 316SS casing and spring, Viton O-Rings.

Engine and Trailer Information

Trailer	Tandem Axle DOT compliant with e-brakes, fenders, lighting, swivel jack, pintle eye coupler
Coupling	SAE Rubber Disk Drive fly-wheel coupling
Engine & Control Panel	Std. 150HP T4F

Note: Consult factory for applications exceeding maximum pressure and/or temperature indicated.

TRASH FLOW®

ENGINE DRIVEN TRASH PUMPS

TFCC-12M™



WASTECORP.
Pumps®

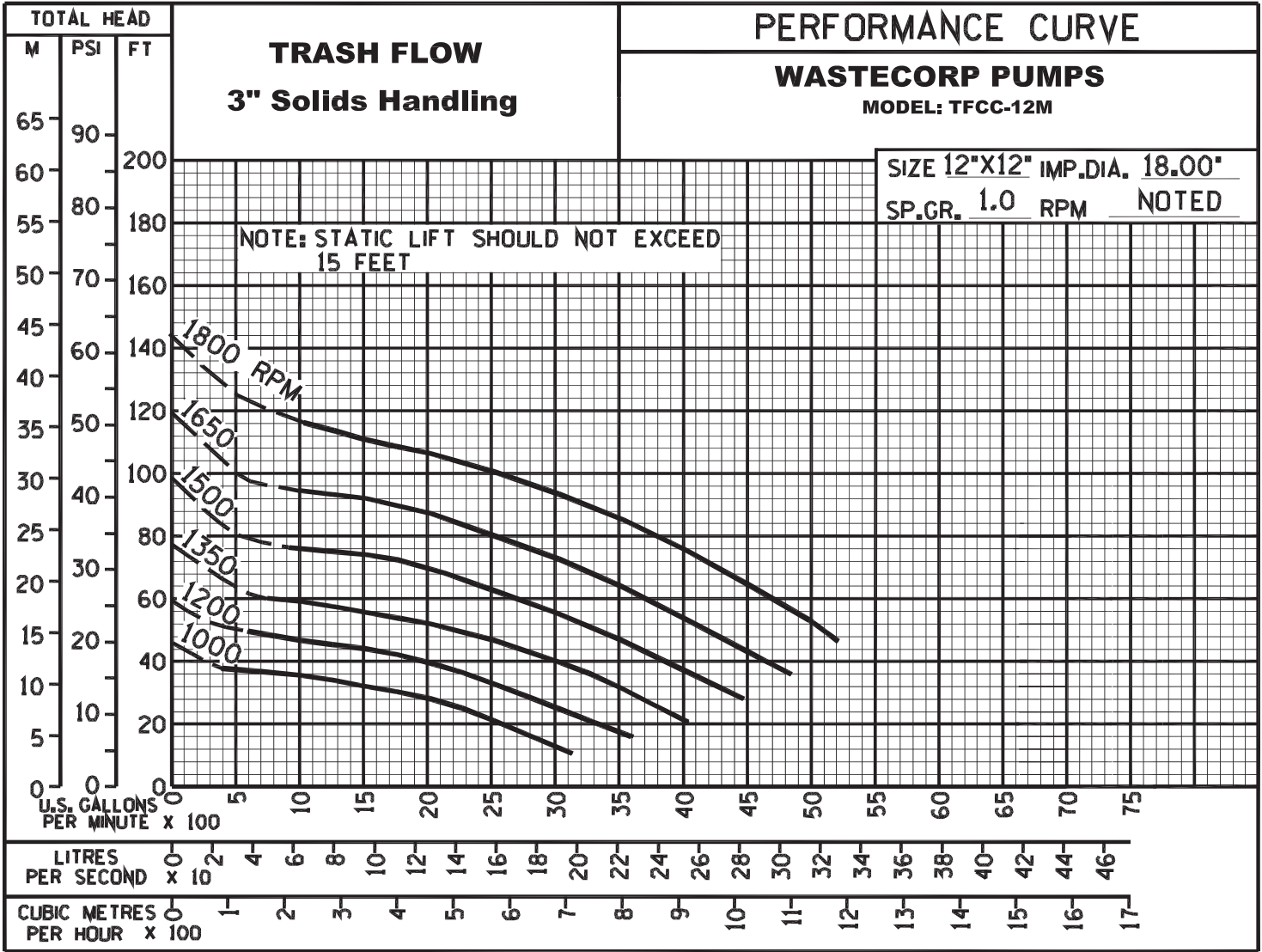

Wastecorp Pumps USA
P.O. Box 70
Grand Island, New York 14072 | USA
Tel: 888.829.2783 | Fax: 888.883.3320
sales@wastecorp.com

Wastecorp Pumps Canada Inc.
50 Shorncliffe Road
Toronto, Ontario M8Z-5K1 | Canada
Tel: 416.233.3000 | Fax: 416.233.2300
info@wastecorp.com

Wastecorp Pumps International
P.O. Box 70
Grand Island, New York 14072 | USA
Tel: 201.445.2882 | Fax: 201.445.3252
techsupport@wastecorp.com