

TRASH FLOW®
HEAVY DUTY 2" TRASH PUMPS
TFCC-2™

FEATURES

TRANSFER UP TO
210 GPM

MAX. HEAD 110 FT. (33M)

HEAVY DUTY BEARINGS
AND CASTINGS

EASILY REMOVABLE
ROTATING ASSEMBLY

OPTIONAL AIR RELEASE
VALVE AVAILABLE

OPTIONAL CASING
HEATER AVAILABLE

HIGH TEMPERATURE
SHUTDOWN KIT
AVAILABLE

DOUBLE FLOATING
MECHANICAL SEAL

*optional

2" x 2"



**THE TFCC-2. THE TOUGH AND COMPACT
SELF PRIMING CENTRIFUGAL PUMP.**

The Trash Flow TFCC-2 is the new standard in 2" self priming centrifugal pumps. You get high quality seals, bearings and impellers with a delivery time up to 50% quicker than comparable makes. The TFCC-2 can pump up to 210 GPM with up to 110 ft. of head. Plus, you have a host of options to configure your 2" self primer exactly the way you need it.

TRASH FLOW® TFCC-2 - OPTIONAL CONFIGURATIONS

FLEX COUPLED



BELT DRIVE VERTICAL



BELT DRIVE PIGGY BACK

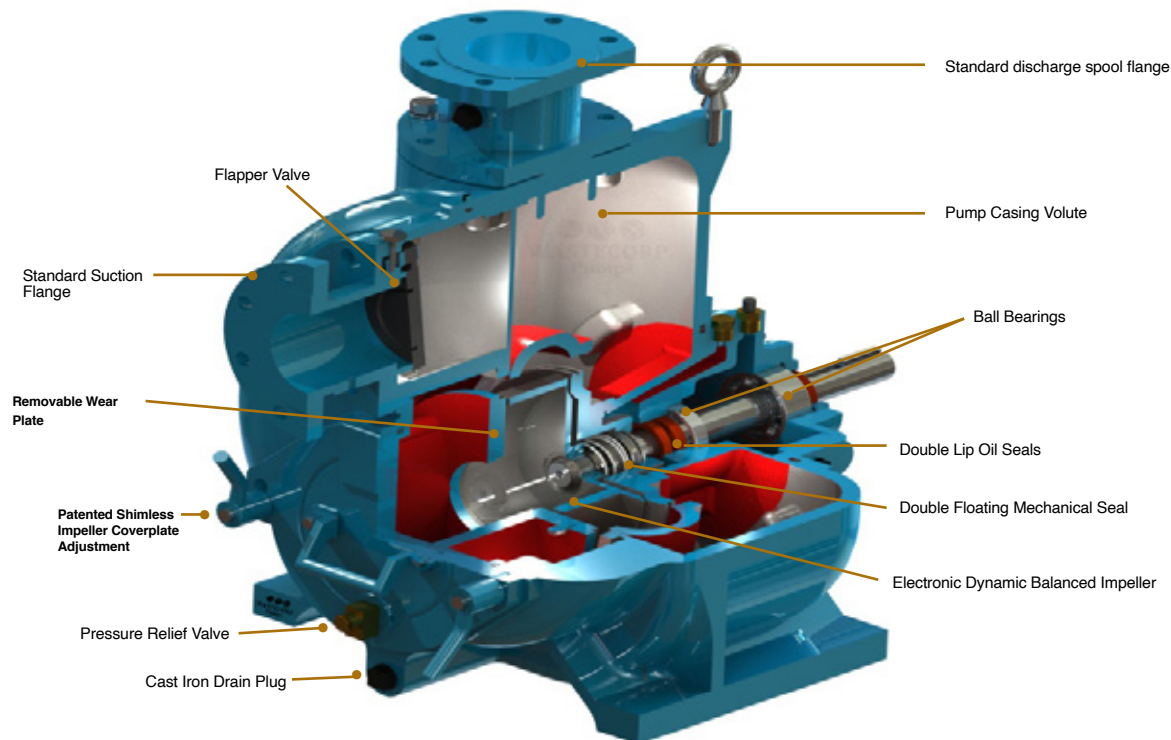

TRASH FLOW®

HEAVY DUTY 2" TRASH PUMPS

TFCC-2™



WASTECORP.
Pumps®

FEATURES



REMOVABLE ROTATING ASSEMBLY

Experience less downtime and maintenance hassles with the Trash Flow's removable rotating assembly. The pump volute and piping are not disturbed during maintenance.

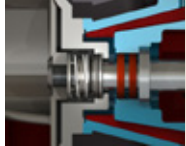

DOUBLE FLOATING MECHANICAL SEAL

Wastecorp's mechanical seals are designed for the harsh pumping conditions in today's municipal and industrial solids handling jobs.



SOLIDS HANDLING IMPELLERS

Trash Flow pumps feature our standard premium two-vane solids handling impellers with solids handling capabilities up to 3" (75mm).



OPTIONAL SUCTION AND DISCHARGE GAUGES

Monitor operating pressure easily with Wastecorp's optional suction and discharge gauges.

OPTIONAL CONFIGURATIONS



SEWAGE LIFT STATIONS

Let our pump designers engineer the ultimate lift station for your facility. We offer complete packaged solutions including control panels, valves and more.



TRAILER OR SKID MOUNT ENGINE

With our trailer or skid mounted diesel engine trash pumps, you'll get a DOT approved solutions for mobile wastewater transfer

Model	Trash Flow® TFCC-2
Connection Size	2" x 2" [50 mm x 50 mm] ANSI/DIN
Max. GPM	210 GPM
Max. Suction Lift	24 ft (7.3m)
Max. Discharge Head	110 ft (33m)
Max. Liquid Temp.	160°F (71°C)
Pump Casing	Grey Iron, ASTM A48; Class 30
Operating Pressure	Maximum 79 psi (545 kPa)
Impeller	Max. 6.38" OD, Ductile Iron ASTM A536, Grade 60-40-18 (Impeller Trimming: If required) Semi-Open Type, Two-Vane Impeller, (two plane, computer dynamically balanced)
Max. Solids Handling	1.5" (38 mm)
Impeller Shaft	ANSI 4140 steel
Replaceable Wear Plate	SAE 1020 steel
Removable Cover Plate	Grey Iron, ASTM A48; Class 30
Flapper Valve	Neoprene with internal steel weight
Bearing Housing	Grey Iron, ASTM A48; Class 30 (includes oil sight glass and breather valve)
Seal Plate	Grey Iron, ASTM A48; Class 30
Shaft Sleeve	316 Stainless Steel
Radial/Thrust Bearing	NSK Open single/Open double
Bearing/Seal Cavity Lubrication	SAE No. 30 Non-Detergent Oil
Gaskets	Buna-N, Compressed Synthetic Fibers, PTFE, Vegetable Fiber, Cork and Rubber
Hardware	Standard Plated Steel, Brass Pressure Relief Valve, Bearing and Seal Cavity Oil Level Sight Gauges
Mechanical Seal	Double floating cartridge type, titanium tungsten carbide rotating and stationary faces, 316SS casing and spring, Viton O-Rings.

Note: Consult factory for applications exceeding maximum pressure and/or temperature indicated.

DIMENSIONAL DRAWING

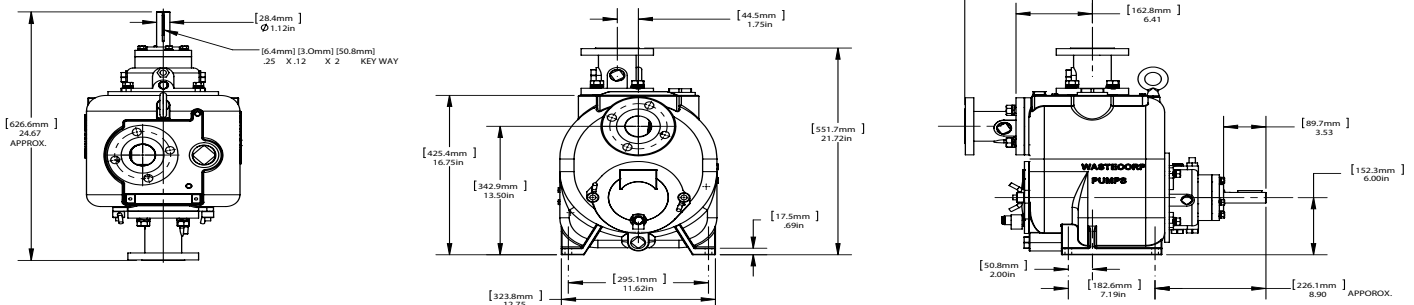

DRAWING NUMBER

63941-00

TRASH FLOW®

HEAVY DUTY 2" TRASH PUMPS

TFCC-2™



WASTECORP.
Pumps®

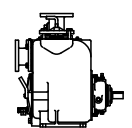
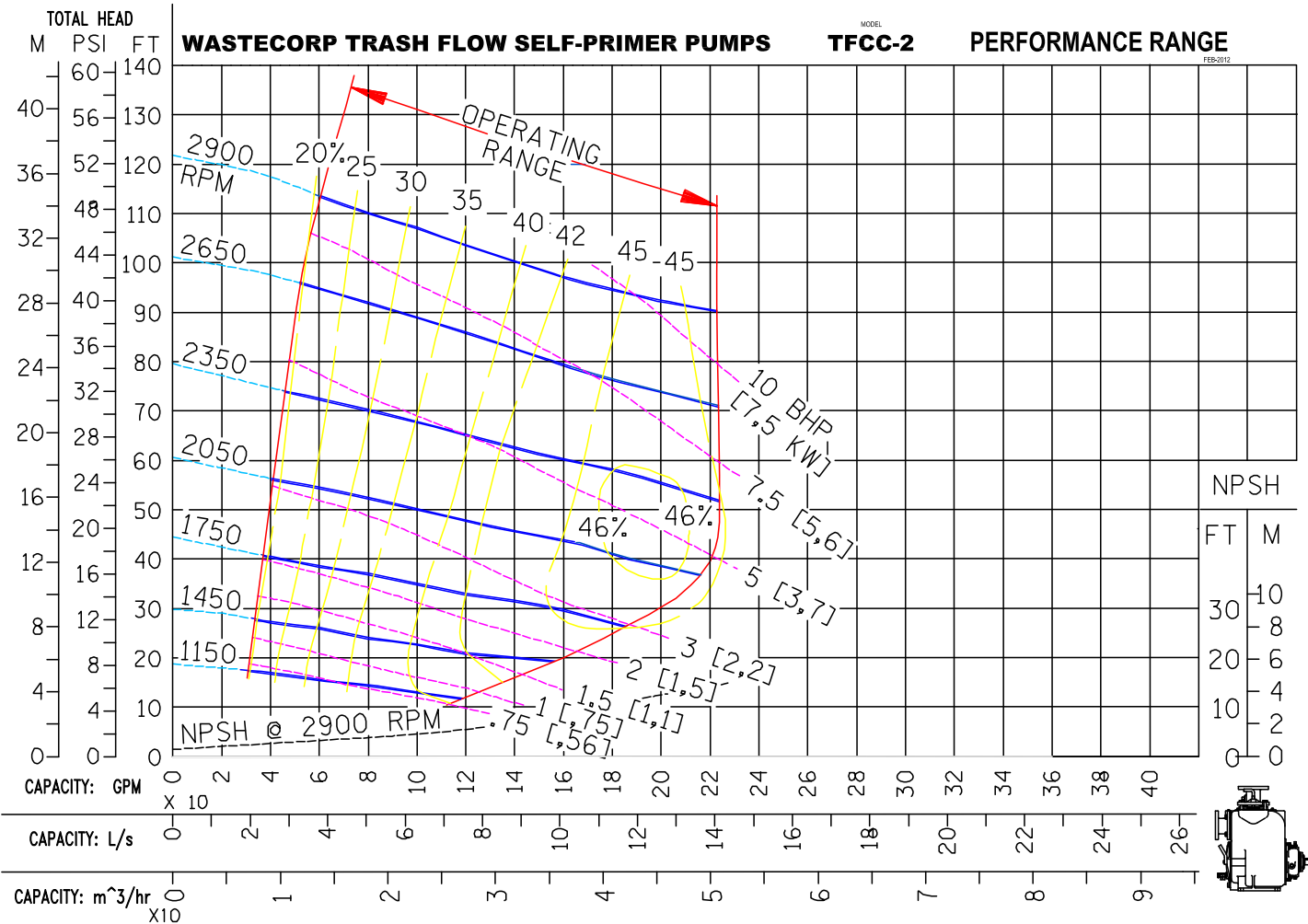

REPRIMING LIFTS

PUMP SPEED	10 FT.	PUMP SPEED	24 FT.
1150 RPM	10 FT.	2650 RPM	24 FT.
1450 RPM	20 FT.	2900 RPM	24 FT.
1750 RPM	24 FT.		
2050 RPM	24 FT.		
2350 RPM	24 FT.		

Determine NPSHr prior to using repriming table. Do not use as available suction lifts.

$$BHP = \frac{GPM \times FT \times SG}{3960 \times Efficiency} \quad KW = \frac{M^3 / HR \times M \times SG}{367 \times Efficiency}$$

Suction lift is limited by the available NPSH which is the corrected atmospheric pressure minus the dynamic suction lift, vapor pressure loss and 2 foot safety factor.



WASTECORP.
Pumps®

www.wastecorp.com

CURVE NO.: 63938-00 **MODEL:** TFCC-2
SIZE: 2" x 2" **IMPELLER DIA:** 6.38"
RPM: VARIOUS **SP. GR.:** 1.0 @ 68°F

Factory certified tests are performed using Hydraulic Institute acceptance Level B. The performance curve shows were taken from actual tests of standard production pumps, and reflect an average performance of the pumps indicated. Wastecorp reserves the right to make changes in design, materials and operating ranges without notice.

WASTECORP
Pumps®
WASTECORP.COM

Wastecorp Pumps USA
P.O. Box 70
Grand Island, New York 14072 | USA
Tel: 888.829.2783 | Fax: 888.883.3320
sales@wastecorp.com

Wastecorp Pumps Canada Inc.
50 Shorncliffe Road
Toronto, Ontario M8Z-5K1 | Canada
Tel: 416.233.3000 | Fax: 416.233.2300
info@wastecorp.com

Wastecorp Pumps International
P.O. Box 70
Grand Island, New York 14072 | USA
Tel: 201.445.2882 | Fax: 201.445.3252
info@wastecorp.com