

TRASH FLOW®
ENGINE DRIVEN TRASH PUMPS
TFCC-8M™

FEATURES

TRANSFER UP TO 2700
GPM (613 M³)

MAX. HEAD 168 FT (51 M)

HEAVY DUTY BEARINGS
AND CASTINGS

EASILY REMOVABLE
ROTATING ASSEMBLY

VACUUM PRIME ASSIST
AVAILABLE*

“SILENT” PUMPING
MODEL AVAILABLE*

QUICK SELF PRIMING
CAPABILITIES

DOUBLE FLOATING
MECHANICAL SEAL

DUAL LIP SEAL BEARING
PROTECTION

*optional



FLAWLESS PERFORMANCE. PROFESSIONAL DURABILITY.

The Wastecorp Trash Flow TFCC-8M engine driven trash pump delivers what no one else can. They have unmatched pumping performance up to 2700 GPM, with a professional trailer or skid frame. With an easy back pullout design, your Trash Flow is also easier to maintain than other makes. Get the power and performance your facility deserves with the new Trash Flow TFCC-8M. Wastecorp is an ISO 9001, ISO 14001 certified pump manufacturer, delivering the quality and environmental responsibility you expect

TRASH FLOW® TFCC-8M - OPTIONAL CONFIGURATIONS



With or Without Wheels The TFCC-8 Moves Wastewater

The TFCC-8M is available as a skid mounted model complete with a heavy duty lifting bail to move around your job site. With a wide variety of diesel engine and control panel options available, you'll get exactly what you need for your job.



**Pumping in Residential Areas?
The Trash Flow Can Quiet Down**

One of the challenges when using a trash pump in residential areas is adhering to local noise regulations. Wastecorp's solution is the Trash Flow Husher with an acoustical hut to keep sound below 70 dBA.



**Intermittent Flow a Problem? “Vacuum Prime Assist” is
The Solution**

Vacuum prime assist is ideal when pumping fluid with large volumes of air or pulling through long suction lines. It is also environmentally friendly as there is no carryover of liquid into the environment because of the unique float box design.

TRASH FLOW®

ENGINE DRIVEN TRASH PUMPS

TFCC-8M™



WASTECORP
Pumps®

FEATURES



REMOVABLE ROTATING ASSEMBLY

Experience less downtime and maintenance hassles with the Trash Flow's removable rotating assembly. The pump volute and piping are not disturbed during maintenance.



DOUBLE FLOATING MECHANICAL SEAL

Wastecorp's mechanical seals are designed for the harsh pumping conditions in today's municipal and industrial solids handling jobs.



SOLIDS HANDLING IMPELLERS

Trash Flow pumps feature our standard premium two-vane solids handling impellers with solids handling capabilities up to 3" (75mm).



OPTIONAL SUCTION AND DISCHARGE GAUGES

Monitor operating pressure easily with Wastecorp's optional suction and discharge gauges.

OPTIONAL CONFIGURATIONS



SEWAGE LIFT STATIONS

Let our pump designers engineer the ultimate lift station for your facility. We offer complete packaged solutions including control panels, valves and more.



SOUND-ATTENUATED ENCLOSURES

When your application calls for an enclosure to reduce noise or provide added security, Wastecorp's Husher® models provide noise reduction below 70 dBA and lockable doors.

Model	Trash Flow® TFCC-8M
Connection Size	8" x 8" (203mm x 203mm) ANSI/DIN
Max. GPM	2700 GPM
Max. Suction Lift	25 ft (7.52m)
Max. Discharge Head	126 ft (38.4m)
Max. Liquid Temp.	160°F (71°C)
Pump Casing	Grey Iron, ASTM A48; Class 30
Operating Pressure	Maximum 120 psi (797 kPa)
Impeller	Max. 14.75" OD, Ductile Iron ASTM A536, Grade 60-40-18 (Impeller Trimming: If required) Semi-Open Type, Two-Vane Impeller, (two plane, computer dynamically balanced)
Max. Solids Handling	3"
Impeller Shaft	ANSI 4140 steel
Replaceable Wear Plate	SAE 1020 steel
Removable Cover Plate	Grey Iron, ASTM A48; Class 30
Flapper Valve	Neoprene with internal steel weight
Bearing Housing	Grey Iron, ASTM A48; Class 30 (includes oil sight glass and breather valve)
Seal Plate	Grey Iron, ASTM A48; Class 30
Shaft Sleeve	316 Stainless Steel
Radial/Thrust Bearing	NSK Open Ball
Bearing/Seal Cavity Lubrication	SAE No. 30 Non-Detergent Oil
Gaskets	Buna-N, Compressed Synthetic Fibers, PTFE, Vegetable Fiber, Cork and Rubber
Hardware	Standard Plated Steel, Brass Pressure Relief Valve, Bearing and Seal Cavity Oil Level Sight Gauges
Mechanical Seal	Double floating cartridge type, titanium tungsten-carbide rotating and stationary faces, 316SS casing and spring, Viton O-Rings.

Trailer Information

Trailer	Single Axle DOT compliant with e-brakes, fenders, lighting, swivel jack, ball hitch or pintle eye coupler
Coupling	SAE Rubber Disk Drive fly-wheel coupling
Engine	JCB Turbo charged 125 hp 444TA4-93 T4F
Fuel Tank	DOT Compliant 80 USG (302.833 L) complete with fuel lines and mounting brackets

Note: Consult factory for applications exceeding maximum pressure and/or temperature indicated.

TRASH FLOW®

ENGINE DRIVEN TRASH PUMPS

TFCC-8M™



WASTECORP
Pumps®

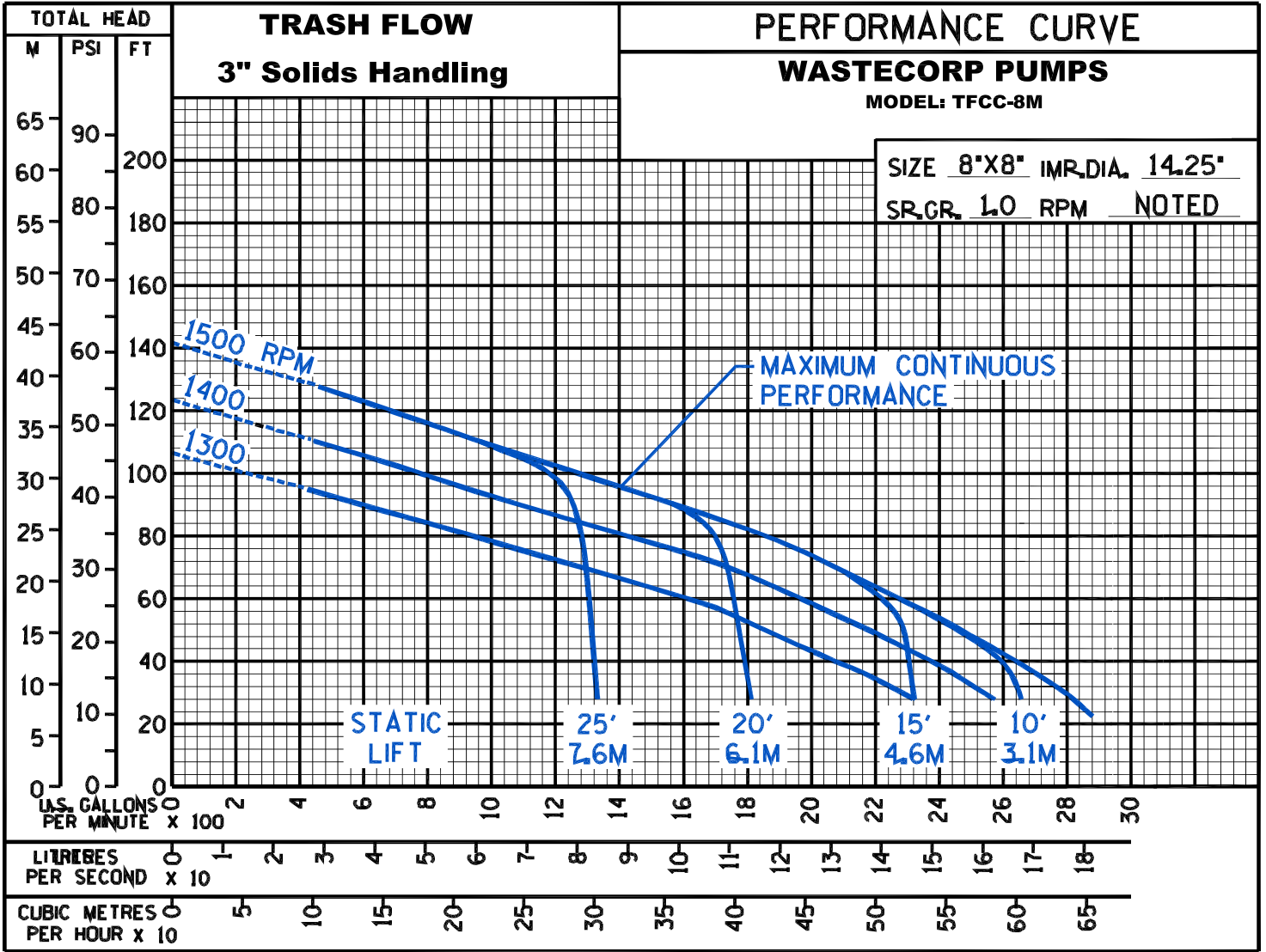

Wastecorp Pumps USA
 P.O. Box 70
 Grand Island, New York 14072 | USA
 Tel: 888.829.2783 | Fax: 888.883.3320
 sales@wastecorp.com

Wastecorp Pumps Canada Inc.
 50 Shorncliffe Road
 Toronto, Ontario M8Z-5K1 | Canada
 Tel: 416.233.3000 | Fax: 416.233.2300
 info@wastecorp.com

Wastecorp Pumps International
 P.O. Box 70
 Grand Island, New York 14072 | USA
 Tel: 201.445.2882 | Fax: 201.445.3252
 techsupport@wastecorp.com

KEY FACTS

Integrated – Engineered – Power solution

High fuel efficiency - SCR only design

Low cost of ownership

High torque at low speed

JCB Global Support

GENERAL TECHNICAL DATA

Model		444 TA4-93
Maximum rating (gross intermittent)	kW (hp)	93 (125)
Thermodynamic cycle		Diesel 4 stroke
Aspiration		TCAE
Arrangement		In-line 4 cylinder IPU
Emissions level		Stage IV / Tier 4
Bore	mm (in)	103 (4.06)
Stroke	mm (in)	132 (5.20)
Total displacement	cm ³ (in ³)	4399 (269)
Valves per cylinder		4
Injection system		Common Rail
Cooling		Liquid
Direction of rotation (viewed from crank nose)		Clockwise
Dry weight	kg (lbs)	710 (1565)
Rated speed	rpm	2200
Peak torque	Nm (lb-ft)	550 (405.7)
Peak torque speed	rpm	1500
Maximum no load governed speed	rpm	2371
Nominal idling speed	rpm	850
Minimum starting temperature without auxiliaries	°C (°F)	-20 (-4)
Gradability - continuous	degrees	35
Gradability - intermittent	degrees	45

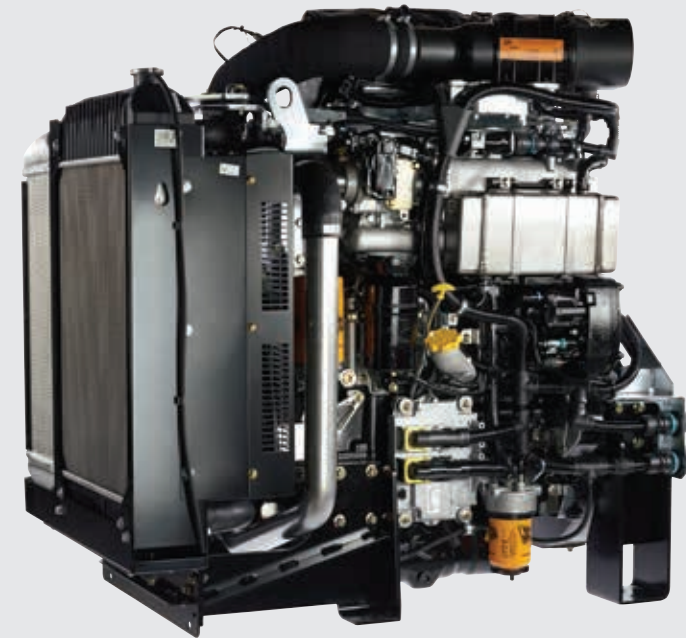
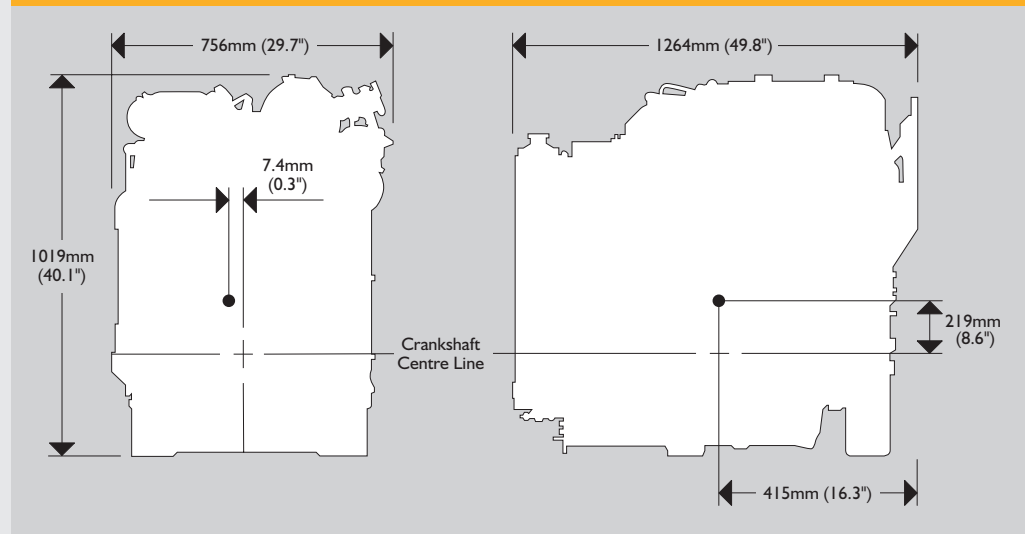
DIMENSIONS

POWER CURVE

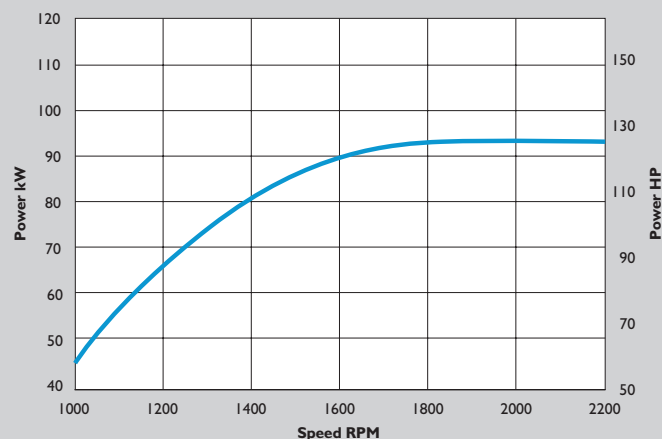

TORQUE CURVE

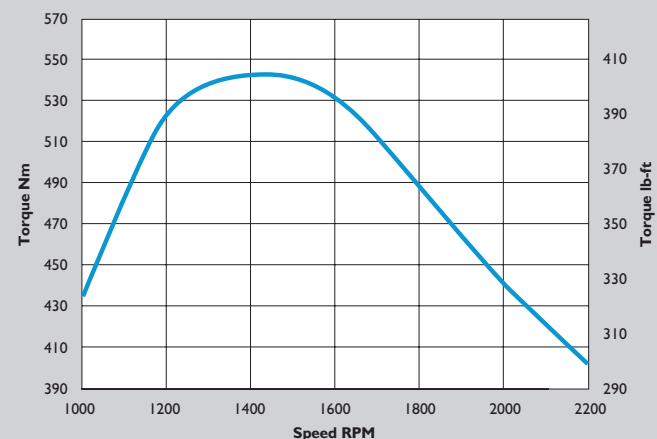

STANDARD CONFIGURATION

Flywheel housing		SAE3
Intake manifold location		Left hand forward
Exhaust manifold / turbocharger location		Right hand rearward
Turbocharger		Wastegate controlled
Fan drive ratios		0.85:1, 1:1, 1.16:1 or 1.25:1
Distance between fan - crankshaft centres	mm (in)	262 (10.3) or 356 (14.0)
Fuel filter		Engine mounted
Fuel lift pump		Pre-filter with primary pump and WIF sensor
Oil filter		Single, vertical - LHS
Oil sump		Pressed steel
Breather system		Open
Oil cooler		Left hand side
Oil filler position		Top and left hand side
Starter motor		12V, 4.2kW
Alternator		12V, 95A
Power Take-off: Heavy Duty		60kW, 205Nm, 1.268:1 RHS
Power Take-off: Light Duty		15kW, 40Nm, 1.625:1 LHS
Finish		Lacquered

*Orientation from flywheel.

EMISSIONS CONTROL SOLUTIONS



OPTIONS

Extensive range of configuration options available - contact local JCB Power Systems dealer, or JCB Power Systems sales and applications department for availability and configuration options.

©2016 JCB Sales. All rights reserved. No part of this publication may be reproduced, stored in a retrieval system, or transmitted in any form or by any other means, electronic, mechanical, photocopying or otherwise, without prior permission from JCB Sales. All references in this publication to operating weights, sizes, capacities and other performance measurements are provided for guidance only and may vary dependant upon the exact specification of machine. They should not therefore be relied upon in relation to suitability for a particular application. Guidance and advice should always be sought from your JCB Dealer. JCB reserves the right to change specifications without notice. Illustrations and specifications shown may include optional equipment and accessories. The JCB logo is a registered trademark of J C Bamford Excavators Ltd.

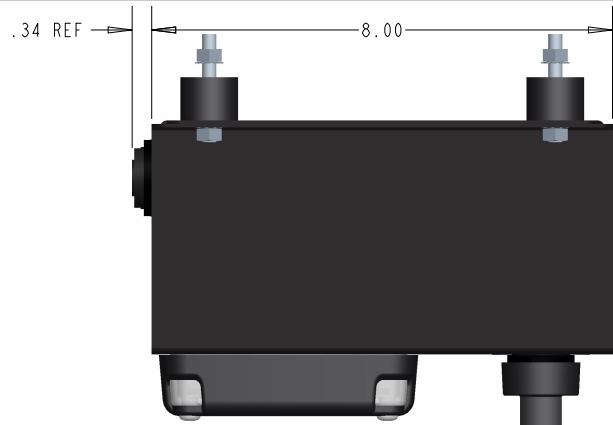

SCALE 0.250

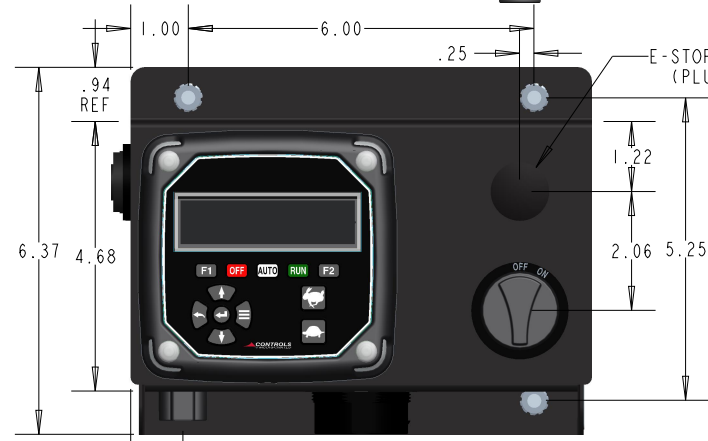

SCALE 0.300

ISOLATION MOUNT,
1/4-20 STUD,
NICKEL PLATED-TYP x4

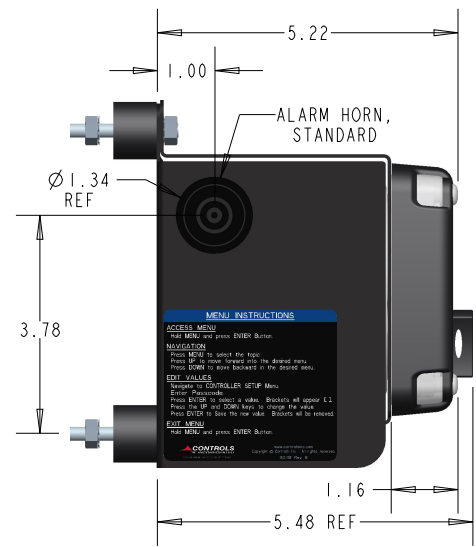
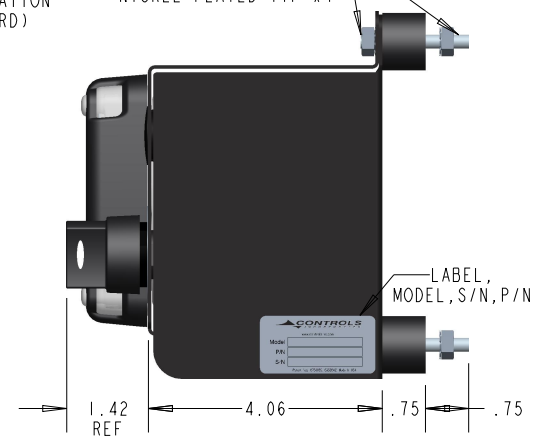

DEUTSCH, DT04-6P-CL09 (SUPPLIED)
REFERENCE CONTROL PANEL MANUAL
FOR PIN ASSIGNMENT DETAILS

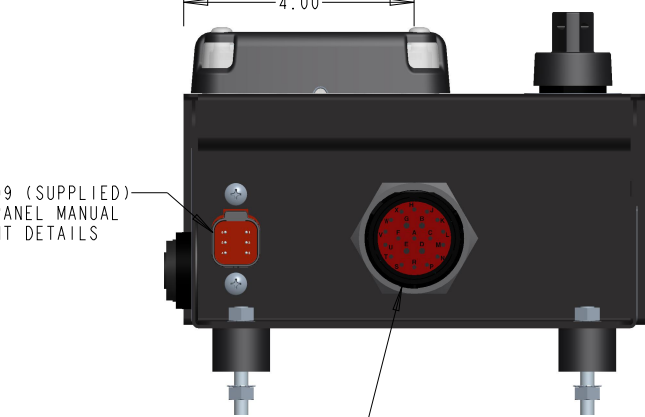

MAIN DEUTSCH CONNECTOR
HDP24-24-21PE (SHOWN/SUPPLIED, J1939)
REFERENCE CONTROL PANEL MANUAL
FOR PIN ASSIGNMENT DETAILS

TOLERANCES ON DIMENSIONS UNLESS OTHERWISE SPECIFIED	
DECIMAL PLACE TOLERANCES	0.0 = ±0.060
	0.00 = ±0.030
	0.000 = ±0.010
ANGLES:	XX = ±0.5°
DRAWING UNITS UNLESS SPECIFIED: INCHES	
DRAWN BY: KLD	DATE: 16-May-19
RELEASE BY: KLD	DATE: 23-Aug-19
MODEL: MX	
CONFIGURATION: 3500-AS	

WWW.CONTROLSINC.COM	330-239-4345
NEXT ASS'Y:	N/A
DESCRIPTION:	CONTROL PANEL ASSEMBLY, 3000 SERIES COMPACT SHEET METAL ENCLOSURE
MATERIAL:	REFERENCE BILL OF MATERIAL
STATUS:	RELEASED
DRAWING NUMBER:	
REVISION:	
SHEET: 1 OF 1	MX-3500-AS

REV:	DATE:	BY:	DESCRIPTION:

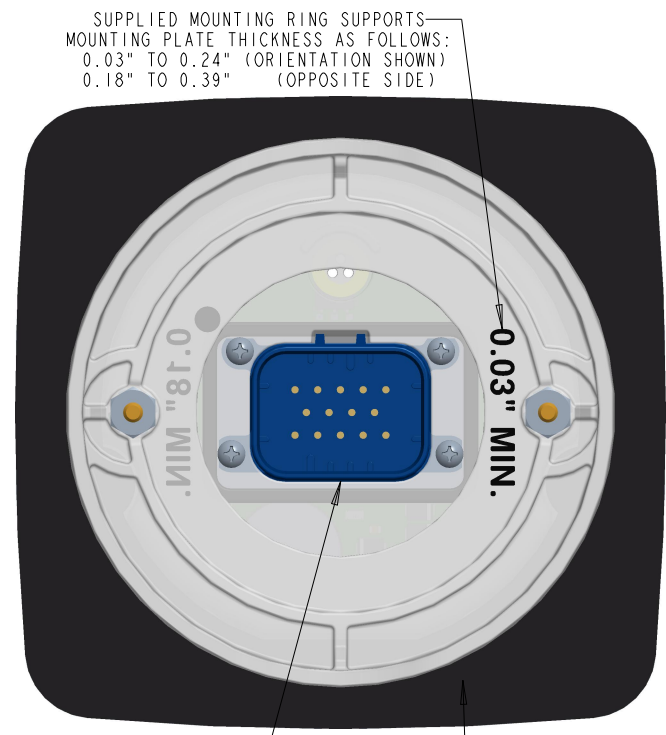

SUPPLIED CONNECTOR:
TYCO/AMP 1-776262-5 (BLUE)
MATES WITH:
TYCO/AMP 776273-5 (BLUE)

OPTIONAL GASKET
9-1034 SHOWN



CONTROLS MX GRAPHICAL SERIES
SCALE 0.500



CONTROLS MX GRAPHICAL SERIES
SCALE 0.500

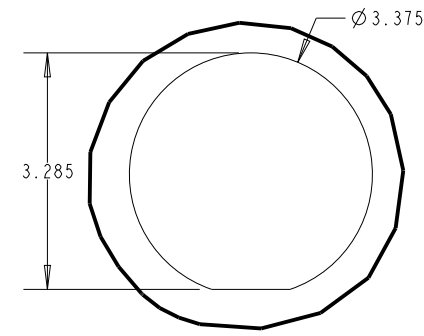

RECOMMENDED
MOUNTING PATTERN
DETAIL C, SCALE 0.375

REV:	DATE:	BY:	DESCRIPTION:

TOLERANCES ON DIMENSIONS UNLESS OTHERWISE SPECIFIED			
DECIMAL PLACE TOLERANCES	0.0 = ±0.060 0.00 = ±0.030 0.000 = ±0.010		
ANGLES:	XX = ±0.5°	NEXT ASS'Y:	MX SERIES PANEL ASSEMBLY
DRAWING UNITS UNLESS SPECIFIED: INCHES		DESCRIPTION:	MX GRAPHICAL ENCLOSURE INSTALLATION DRAWING
DRAWN BY: KLD	DATE: 30-Aug-19	MATERIAL:	REFERENCE BILL OF MATERIAL
CHECKED BY:	DATE:	STATUS:	RELEASED
MODEL: MX		DRAWING NUMBER:	MX_SERIES
CONFIGURATION: MX GRAPHICAL		REV:	-

MX SERIES INPUT/OUTPUT OPTIONS

PCB 8100-100, Version 1.0, BOM 1.0

PIN	DEFAULT	OPTIONS
1	DO 1	None
2	DO 2	None
3	FREQ IN	None
4	DO 3	MODBUS B
5	DO 4	MODBUS A
6	AI 3	4mA R, 4-20mA, 0-5 VDC
7	CAN H	J1939
8	CAN L	J1939
9	DI 2	None
10	AI 2	12mA R, 4-20mA, 0-5 VDC
11	B+	8-32 VDC
12	GND	None
13	AI 1	12mA R, 4-20mA, 0-5 VDC
14	DI 1	None

KEY

DO	Digital Output, 5 Amp Max, Vbatt
FREQ IN	MPU, Alt Tach or Sq Wave; 3 V min
AI	Analog Input, Wetting Current Resistive, Current, Active Voltage
DI	Digital Input, V Batt wetting current; close to GROUND



776262-5
MODULE CONNECTOR
SCALE 1.000

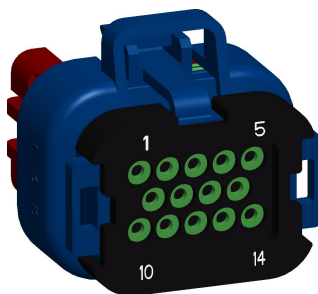

776273-05
770854-1 TERMINAL, TIN PLATED
770854-3 TERMINAL, GOLD PLATED
SCALE 1.000

REV:	DATE:	BY:	DESCRIPTION:

TOLERANCES ON DIMENSIONS UNLESS OTHERWISE SPECIFIED			
DECIMAL PLACE TOLERANCES	0.0 = ±0.060	WWW.CONTROLSINC.COM 330-239-4345	
	0.00 = ±0.030	NEXT ASS'Y:	MX SERIES PANEL ASSEMBLY
	0.000 = ±0.010	DESCRIPTION:	MX MODULE, 14-PIN AMP, PIN CONFIGURATIONS
ANGLES:	XX = ±0.5°	DRAWING UNITS UNLESS SPECIFIED: INCHES	
DRAWN BY: KLD	DATE: 03-Sept-19	MATERIAL: REFERENCE BOM / DETAIL DWG	
CHECKED BY:	DATE:	STATUS: RELEASED	
MODEL: MX		DRAWING NUMBER:	REV:
CONFIGURATION: MX GRAPHICAL	SHEET: 2 OF 2	MX_SERIES	-