

TRASH FLOW®
TFCCH-4™

H Series - High Head



FEATURES

MAX. HEAD: 190 FT.

MAX. FLOW: 640 GPM

HEAVY DUTY BEARINGS
AND CASTINGS

EASILY REMOVABLE
ROTATING ASSEMBLY

QUICK SELF PRIMING
CAPABILITIES

DOUBLE FLOATING
MECHANICAL SEAL

DUAL LIP SEAL BEARING
PROTECTION

*optional

BETTER PERFORMANCE. QUICKER DELIVERY.
THAT'S TRASH FLOW TFCCH-4.™

TRASH FLOW® SELF PRIMING CENTRIFUGAL PUMPS- TFCCH-4 SPECIFICATIONS

Model	Trash Flow® TFCCH-4
Connection Size	4" x 4" [102 mm x 102 mm] ANSI/DIN
Max. Head	190 ft.(57 m)
Max Flow	640 GPM (145 m ³ /h)
Bare Pump Weight	662 lbs (300 kg)
Max. Casing Pressure	128 psi (883 kPa)
Pump Casing	Grey Iron, ASTM A48; Class 30
Impeller	Six vane, Semi-open
Max. Solids Handling	1-1/8"
Impeller Shaft	ANSI 4140 steel
Replaceable Wear Plate	SAE 1020 steel
Removable Cover Plate	Grey Iron, ASTM A48; Class 30
Flapper Valve	Neoprene with internal steel weight
Bearing Housing	Grey Iron, ASTM A48; Class 30 (includes oil sight glass and breather valve)
Seal Plate	Grey Iron, ASTM A48; Class 30
Shaft Sleeve	316 Stainless Steel
Radial/Thrust Bearing	NSK Open Ball
Bearing/Seal Cavity Lubrication	SAE No. 30 Non-Detergent Oil
Gaskets	Buna-N, Compressed Synthetic Fibers, PTFE, Vegetable Fiber, Cork and Rubber
Hardware	Standard Plated Steel, Brass Pressure Relief Valve, Bearing and Seal Cavity Oil Level Sight Gauges
Mechanical Seal	Double floating cartridge type, titanium tungsten-carbide rotating and stationary faces, 316SS casing and spring, Viton O-Rings.
Optional Equipment	Lift station Pressure relief valve Acoustical enclosure Temperature shutdown Specialty seals (call factory) Air release valve Trailer mounted kit Wastecorp hard iron impeller

Note: For information purposes only not to be used for construction. Subject to change without notice. Consult factory for applications exceeding maximum pressure and/or temperature indicated.

• info@wastecorp.com
• 1-888-829-2783

WASTECORP.COM

PUMP DIMENSIONS

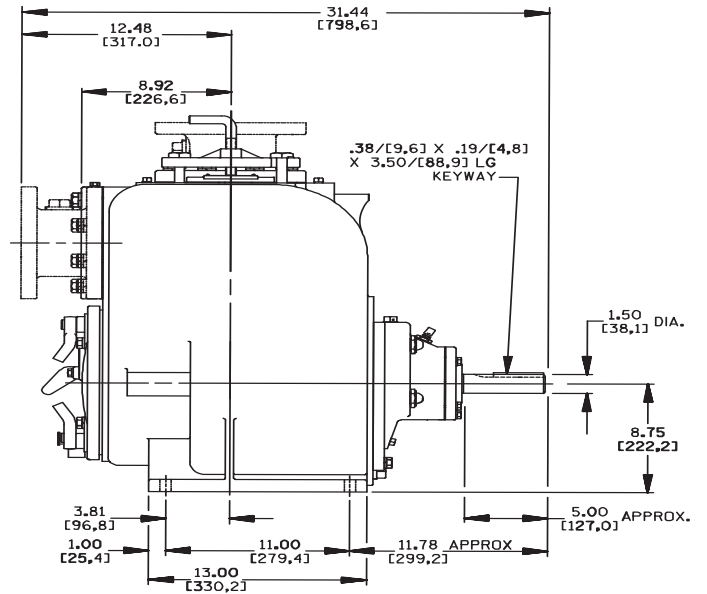
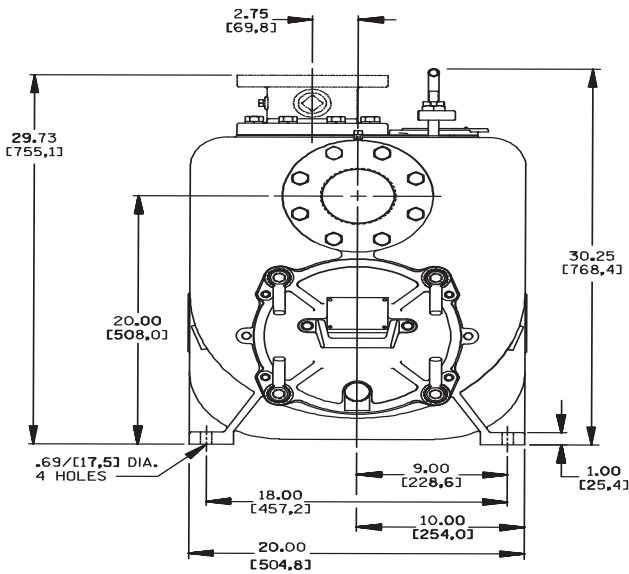
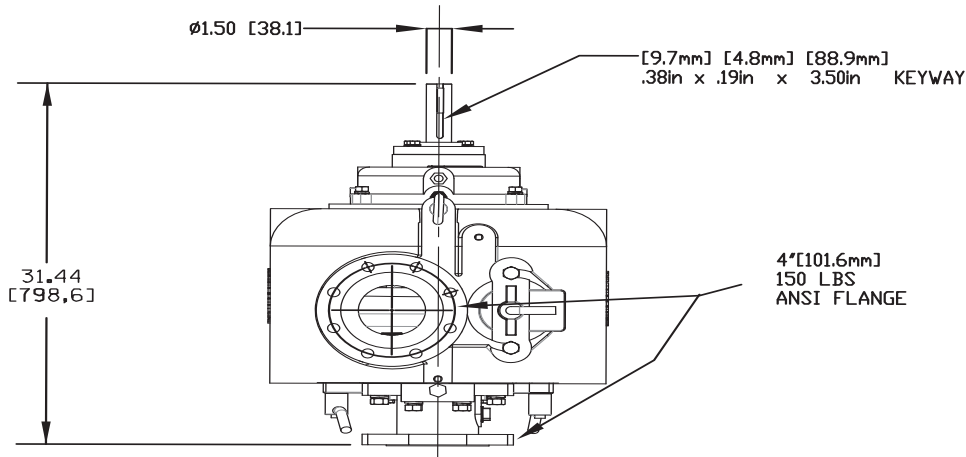

TFCCH-4 Self Priming Centrifugal Pump Performance Curve

