



2025 SUPER DUTY® VACUUM PUMP BROCHURE
SLIDE-IN VACUUM UNITS
VACUUM TRAILERS
VACUUM TRUCKS



PUMPS DESIGNED FOR ONE APPLICATION. YOURS.

Demonstrated Engineering Excellence in The Pump Manufacturing Industry.

Solving your fluid handling challenge is what Wastecorp Pumps is committed to everyday. We have the right support team, pump products and services for your application. Wastecorp provides competitive pricing, unbeatable quality and industry leading quick turnaround time for your project no matter where it is.

Disrupting conventional wisdom in pump manufacturing is what keeps Wastecorp growing. We design innovative pump products with the latest energy saving drive systems to enhance your productivity and your budget.

As an ISO 9001 certified pump company, Wastecorp Pumps is committed to providing exceptional quality, valuable support and guidance throughout the life cycle. Our tireless commitment to end users, unparalleled quality and fast delivery times sets Wastecorp apart from the crowd.

NEXT GENERATION PUMP MANUFACTURING

Wastecorp Pumps is an ISO 9001 certified pump manufacturing company. We follow Hydraulic Institute standards in making sure your pump is of world class quality. If you ever have a question throughout the life cycle of your pump, a Wastecorp expert is a quick phone call away and so are parts for your pump.

EXPERT STAFF

From Wastecorp project managers to our welders, millwrights, engineers and assembly team, you get a dedicated support staff averaging 10 years of Wastecorp service. Some of our team members are approaching 25 years of service. We have worked with almost every fluid handling application on earth. With Wastecorp, you get the right people to guide you through your pump selection.



PARTS AND SERVICE

When you need genuine factory repair parts for your vacuum pump system, you'll get them when you need them. We stock thousands of genuine Wastecorp repair parts and process your order within 24 hours.

Should you ever require service or support for your pump, you get free telephone support with your new pump. On site service may also be arranged through Wastecorp's network of factory authorized technicians.



CUSTOM SOLUTIONS

You think outside of the box and so does Wastecorp. Discuss your application with Wastecorp's engineering support hotline and we will assist you in finding the right solution for your pumping needs. Contact us at 1-888-829-2783 or email info@wastecorp.com



DUAL COMPARTMENT VACUUM PUMPS. WASTE AND FRESH WATER IN ONE TANK.

Most applications benefit by having a method to provide rinse down services or fresh water after the waste has been pumped. Wastecorp offers dual compartment vacuum pump systems for almost every model we manufacture. You can customize the size of each compartment to get exactly the waste and fresh water compartment you need. Each compartment contains its own pump and hosing system and does not add to the footprint of the system in most cases.

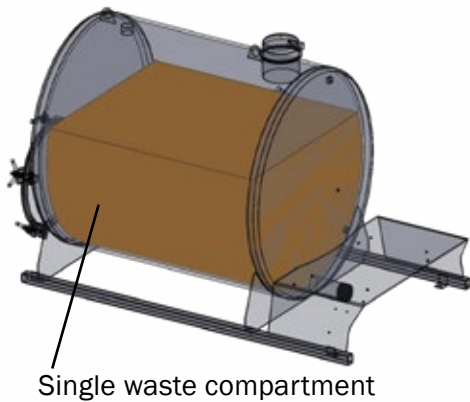

Waste Tank (Single Compartment)

If your application exclusively calls for waste pumping using a vacuum pump, then our Super Duty TVP waste tank pump is the solution for you.

All tanks are available in steel or optional stainless steel and a variety of finishes designed specifically for your job environment.

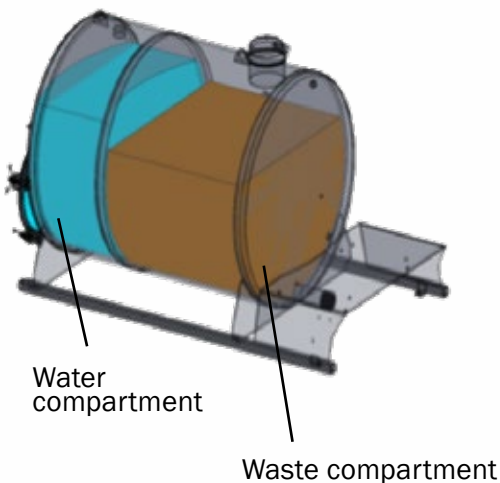

Waste + Fresh Water (Dual Compartment)

Have the best of both worlds with a waste tank and fresh water source all in the same system. In this innovative design, the tank is divided between waste and fresh water holding areas complete with their own pump. You also have a standard sight glass/tube on each to visually identify the volume in each tank. Select from 100, 150, 200 and 260 gallon fresh water compartments.

With a variety of configuration options, Wastecorp's skid mounted honey wagons can be mounted almost anywhere such as golf carts, pump out boats and more.

ENHANCE YOUR PRODUCTIVITY WITH A SUPER DUTY DUAL COMPARTMENT VACUUM PUMP.

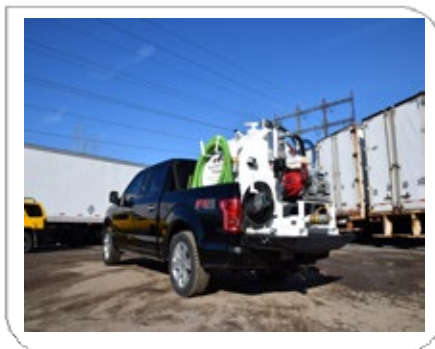

Separate Waste and Water Compartments Trailer Mounted or Slide-In Available

Compact Footprint

COMPACT MOBILE VACUUM SYSTEMS FOR ATV AND UTILITY VEHICLE TOWING

If you need a powerful vacuum pump system but have space constraints, look no further than Wastecorp's Super Duty ATV Series Vacuum Pumps. The ATV Series offers a smaller foot print for towing with ATV's or sliding into an ATV bed like John Deere Gators, Cub Cadet Challenger, Polaris Ranger, Bobcat UTV's and more. Contact a Vacuum Pump expert at Wastecorp to customize your system.



ULTRACOMPACT

Designed for lower volumes where a powerful vacuum pump is required. 25-50 gallon sizes. Can be towed with an ATV or mounted in a utility vehicle bed. Customize to your specifications.



COMPACT

For medium volume pumping applications within a compact foot print. Tank sizes range from 100-250 gallons and are towable by an ATV or truck. High suction power and dual compartment waste and water capable.



SPECIALTY

Super Duty Specialty vacuum pumps are designed for specific industries like, industrial chemical pumping, marine sewage pumping, municipal bus oil transfer applications and more. Customized with industry specific components and accessories.

SMALL FOOTPRINT. POWERFUL PUMPING. SUPER DUTY COMPACT SERIES.



ATV Towing Capable



Slide-In Vacuum Pumps For ATV's



Specialty Vacuum Pumps
For Specific Applications

TRAILER MOUNTED VACUUM PUMPS. THE QUALITY AND PERFORMANCE YOU ARE LOOKING FOR.

Your vacuum pump trailer is an investment. Don't settle for anything less than the high quality manufacturing of Wastecorp's Super Duty trailer mounted vacuum pumps. Wastecorp's trailer systems include galvanized trailer frames to withstand weather, LED lighting systems, your choice of manway sizes, vacuum power and engine options. Wastecorp has a 30 year track record with customers just like you and we stand behind every product we sell.



SINGLE AXLE

50-300 gallon sizes



DOUBLE AXLE

500-1200 gallon sizes



TRIPLE AXLE

1500-2000 gallon sizes



Optional Two Pump System

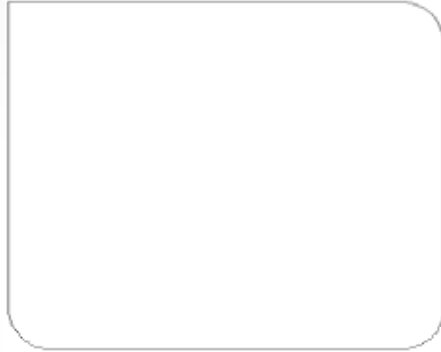

Optional Tilt Tank Automated System



Optional Automated Jack System



Super Duty Ultra Compact Vacuum Pumps



TVP-50, 50 gallon model shown with turf tires and ATV tow package.



Rear view. Optional manway shown.

TVP-25-75 Series

Mounting options	ATV tow package (shown above), turf tire trailer mounted, standard tire trailer mounted or stationary.
Tank	Your choice of 25, 50 or 75 gallon tanks. Standard steel, optional stainless steel.
Hoses and fittings	Qty: 1 - Select either 2"x30' or 3" x 30 ft suction non-collapsible EPDM hose (Grn/Blk) with camlocks. Includes clear swing check valve and ball valve and female camlock to connect optional accessories.
Standard Pump/Engine	9 hp Honda gas engine (127 CFM). See optional drives for higher HP and CFM (vacuum power).
Pump options	9 HP Honda Gas Engine (127 CFM) 13 HP Honda Gas Engine (230 CFM) 10 HP Kohler Diesel Engine (127 CFM) 13 HP Kohler Diesel Engine (230 CFM) 24 hp Honda Gas or Kohler Diesel (363 CFM) 30 HP Kohler Diesel Engine (520 CFM)
Applications	Septic pumping services, waste trap grease pumping, car wash/wash bay pump out, general wastewater pump

TVP-25-75 Series

Model
TVP-25 - ATV Package Slide-in Unit Wagon Mounted
TVP-50 - ATV Package Slide-in Unit Wagon Mounted
TVP-75 - ATV Package Slide-in Unit Wagon Mounted

Accessories/Configuration Options

Description
2" x 50 ft Non-Collapsible Suction Hose
3" x 50 ft Non-Collapsible Suction Hose
30" Sch. 80 PVC Wand;
Rear access manway Select either 20", 25" or 36" diameter
Sight glass
Trailer mounted toolbox
Trailer mounted hose box
Rear end or side mounted pump (Front mount standard)
Tank level indicator
Hydraulic tilt tank (Tilt-N-Go™)
Dual compartment waste and water

Super Duty Compact Pump Series



TVP-150 Series with ATV tow package. 150 gallon tank. Slide-in unit available. Standard front mount vacuum pump with hose rack.



Rear view.

TVP-100-250 Series

Mounting options	DOT Compliant trailer mounted, single axle with electric brakes and LED lighting package. Galvanized frame. Slide-in, skid mounted unit also available.
Tank	100, 150, 200 or 250 gallon steel tank. Single waste compartment standard (dual compartment, waste and water also available)
Hoses and fittings	Qty: 1 - Select either 2"x30' or 3" x 30 ft suction non-collapsible EPDM hose (Grn/Blk) with camlocks. Includes clear swing check valve and ball valve and female camlock to connect optional accessories.
Standard Pump/Engine	9 hp Honda gas engine (127 CFM). Larger engine sizes and enhanced vacuum power available. See below.
Pump options	9 HP Honda Gas Engine (127 CFM) 13 HP Honda Gas Engine (230 CFM) 10 HP Kohler Diesel Engine (127 CFM) 13 HP Kohler Diesel Engine (230 CFM) 24 hp Honda Gas or Kohler Diesel (363 CFM) 30 HP Kohler Diesel Engine (520 CFM)
Applications	Septic pumping services, waste trap grease pumping, car wash/wash bay pump out, general wastewater pump

TVP-100-250 Series

Model
TVP-100 - ATV Package Slide-in Unit Wagon Mounted
TVP-150 - ATV Package Slide-in Unit Wagon Mounted
TVP-200 - ATV Package Slide-in Unit Wagon Mounted
TVP-250 - ATV Package Slide-in Unit Wagon Mounted

Accessories/Configuration Options

Description
2" x 50 ft Non-Collapsible Suction Hose
3" x 50 ft Non-Collapsible Suction Hose
Rear access manway Select either 20", 25" or 36" diameter
Sight glass
Trailer mounted toolbox
Trailer mounted hose box
Rear end or side mounted pump (Front mount standard)
Tank level indicator
Hydraulic tilt tank (Tilt-N-Go™)
Dual compartment waste and water

Super Duty TVP 300 Series Vacuum Pumps



TVP-300 Series with standard front mount vacuum pump. 300 gallon tank.



Rear view

TVP 300 Series

Mounting options	DOT Compliant trailer mounted, single axle with electric brakes and LED lighting package. Galvanized frame. Slide-in, skid mounted unit also available.
Tank	300 gallon steel tank. Single waste compartment standard (dual compartment, waste and water also available)
Hoses and fittings	Qty: 1 - Select either 2"x30' or 3" x 30 ft suction non-collapsible EPDM hose (Grn/Blk) with camlocks. Includes clear swing check valve and ball valve and female camlock to connect optional accessories.
Standard Pump/Engine	9 hp Honda gas engine (127 CFM). Larger engine sizes and enhanced vacuum power available. See below.
Pump options	9 HP Honda Gas Engine (127 CFM) 13 HP Honda Gas Engine (230 CFM) 10 HP Kohler Diesel Engine (127 CFM) 13 HP Kohler Diesel Engine (230 CFM) 24 hp Honda Gas or Kohler Diesel (363 CFM) 30 HP Kohler Diesel Engine (520 CFM)
Applications	Septic pumping services, waste trap grease pumping, car wash/wash bay pump out, general wastewater pump

TVP-300 Series

Model
TVP-300-DT Trailer Mounted
TVP-300-S - Slide-in unit, stationary

Accessories/Configuration Options

Description
25' suction/discharge hose increments (with camlocks)
30" Sch. 80 PVC Wand;
Rear access manway Select either 20", 25" or 36" diameter
Sight glass
Trailer mounted toolbox
Trailer mounted hose box
Rear end or side mounted pump (Front mount standard)
Tank level indicator
Hydraulic tilt tank (Tilt-N-Go™)
Dual compartment waste and water

Shown: Super Duty Trailer Mounted Vacuum Pump TVP-450 Series DOT compliant.
Shown with optional potty wand and automated hydraulic tilt tank function with lockable
optional storage bin.



SUPER DUTY TILT-N-GO™

THE ULTIMATE VACUUM PUMP WITH TILT FUNCTION TO EMPTY OR RINSE TANK.

Steel, or stainless steel tanks available (powder coated white shown)

Make quick work of emptying your tank. The Super Duty Tilt-N-Go vacuum pump from Wastecorp allows you to quickly tilt the tank, empty your load and get on with your day. Plus a huge man way opens for you to rinse the tank.



Raise or lower the trailer with Wastecorp's optional Push button automated or manual hitch. (manual hitch shown)

Lockable storage bins for the ultimate in convenience and security (Pro Pumper storage bin shown)

2" ball hitch or 3" pintle hook connection available (3" pintle hook shown)

TILT THE TANK AT THE TOUCH OF A BUTTON

High powered 92-363 CFM vacuum pump available

Select from 200-2000 gallon tank sizes (500 gallon shown)



Tilt function allows you to empty the tank into a dumpster or other compliant area

DOT approved trailer package with optional LED lights and electric brakes

Galvanized frame to withstand hot or cold weather (standard frame shown)

Single, double or triple axle trailers available (double axle shown)



Super Duty TVP 450 Series Vacuum Pumps



TVP-450, 450 gallon model shown with DOT compliant trailer and optional storage bin.



Rear view. Optional manway shown.

TVP 450 Series

Mounting options	DOT compliant trailer mounted or slide-in stationary unit.
Tank	Your choice of 450 gallon single compartment waste or dual compartment waste and water.
Hoses and fittings	Qty: 1 - Select either 2"x30' or 3" x 30 ft suction non-collapsible EPDM hose (Grn/Blk) with camlocks. Includes clear swing check valve and ball valve and female camlock to connect optional accessories.
Standard Pump/Engine	9 hp Honda gas engine (127 CFM). Larger engine sizes and enhanced vacuum power available. See below.
Pump options	9 HP Honda Gas Engine (127 CFM) 13 HP Honda Gas Engine (230 CFM) 10 HP Kohler Diesel Engine (127 CFM) 13 HP Kohler Diesel Engine (230 CFM) 24 hp Honda Gas or Kohler Diesel (363 CFM) 30 HP Kohler Diesel Engine (520 CFM)
Applications	Septic pumping services, waste trap grease pumping, car wash/wash bay pump out, general wastewater pump

TVP-450 Series

Model
TVP-450 - DOT compliant trailer mounted
TVP-450 - DOT compliant trailer mounted with tilt tank - hydraulic tank tilting system
TVP-450 - Stationary slide-in unit
TVP-350-100 - Dual compartment 350 gallon waste, 100 gallon fresh water

Accessories/Configuration Options

Description
3" x 50 ft Non-Collapsible Suction Hose
30" Sch. 80 PVC Wand;
Rear access manway Select either 20", 25" or 36" diameter
Sight glass
Trailer mounted toolbox
Trailer mounted hose box
Rear end or side mounted pump (front mount standard)
Tank level indicator
Hydraulic tilt tank (Tilt-N-Go™)
Dual compartment waste and water

Super Duty TVP 500 Series Vacuum Pumps



TVP-500, 500 gallon model shown with galvanized frame, diamond plate deck and DOT compliant trailer system. Optional beacon light and LED work lights also shown.

TVP 500 Series

Mounting options	DOT compliant trailer mounted or slide-in stationary unit.
Tank	Your choice of 500 gallon single compartment waste or dual compartment waste and water.
Hoses and fittings	Qty: 1 - Select either 2"x30' or 3" x 30 ft suction non-collapsible EPDM hose (Grn/Blk) with camlocks. Includes clear swing check valve and ball valve and female camlock to connect optional accessories.
Standard Pump/Engine	9 hp Honda gas engine (127 CFM). Larger engine sizes and enhanced vacuum power available. See below.
Pump options	9 HP Honda Gas Engine (127 CFM) 13 HP Honda Gas Engine (230 CFM) 10 HP Kohler Diesel Engine (127 CFM) 13 HP Kohler Diesel Engine (230 CFM) 24 hp Honda Gas or Kohler Diesel (363 CFM) 30 HP Kohler Diesel Engine (520 CFM)
Applications	Septic pumping services, waste trap grease pumping, car wash/wash bay pump out, general wastewater pump

TVP-500 Series

Model
TVP-500 - DOT compliant trailer mounted
TVP-500 - DOT compliant trailer mounted with tilt tank - hydraulic tank tilting system
TVP-500 - Stationary slide-in unit
TVP-350-150 - Dual compartment 350 gallon waste, 150 gallon fresh water

Accessories/Configuration Options

Description
3" x 50 ft Non-Collapsible Suction Hose
30" Sch. 80 PVC Wand;
Rear access manway Select either 20", 25" or 36" diameter
Sight glass
Trailer mounted toolbox
Trailer mounted hose box
Rear end or side mounted pump (front mount standard)
Tank level indicator
Hydraulic tilt tank (Tilt-N-Go™)
Dual compartment waste and water

Super Duty TVP 800 Series Vacuum Pumps



TVP-800 Series with 800 gallon tank.



Rear view. Optional manway shown.

TVP 800 Series

Mounting options	DOT compliant trailer mounted or slide-in stationary unit.
Tank	Your choice of 800 gallon single compartment waste or dual compartment waste and water.
Hoses and fittings	Qty: 1 - Select either 2"x30' or 3" x 30 ft suction non-collapsible EPDM hose (Grn/Blk) with camlocks. Includes clear swing check valve and ball valve and female camlock to connect optional accessories.
Standard Pump/Engine	9 hp Honda gas engine (127 CFM). Larger engine sizes and enhanced vacuum power available. See below.
Pump options	9 HP Honda Gas Engine (127 CFM) 13 HP Honda Gas Engine (230 CFM) 10 HP Kohler Diesel Engine (127 CFM) 13 HP Kohler Diesel Engine (230 CFM) 24 hp Honda Gas or Kohler Diesel (363 CFM) 30 HP Kohler Diesel Engine (520 CFM)
Applications	Septic pumping services, waste trap grease pumping, car wash/wash bay pump out, general wastewater pump

TVP-800 Series

Model
TVP-800 - DOT compliant trailer mounted
TVP-800 - DOT compliant trailer mounted with tilt tank - hydraulic tank tilting system
TVP-800- Stationary slide-in unit
TVP-600-200 - Dual compartment 600 gallon waste, 200 gallon fresh water

Accessories/Configuration Options

Description
3" x 50 ft Non-Collapsible Suction Hose
30" Sch. 80 PVC Wand;
Rear access manway Select either 20", 25" or 36" diameter
Sight glass
Trailer mounted toolbox
Trailer mounted hose box
Rear end or side mounted pump (front mount standard)
Tank level indicator
Hydraulic tilt tank (Tilt-N-Go™)
Dual compartment waste and water

Super Duty TVP 1000 Series Vacuum Pumps



TVP-1000, 1000 gallon model shown with galvanized frame, diamond plate deck and DOT compliant trailer system. Optional extended deck model shown.

Rear view. Optional manway shown.

TVP 1000 Series

Mounting options	DOT compliant trailer mounted or slide-in stationary unit.
Tank	Your choice of 1000 gallon single compartment waste or dual compartment waste and water.
Hoses and fittings	Qty: 1 - Select either 2"x30' or 3" x 30 ft suction non-collapsible EPDM hose (Grn/Blk) with camlocks. Includes clear swing check valve and ball valve and female camlock to connect optional accessories.
Standard Pump/Engine	9 hp Honda gas engine (127 CFM). Larger engine sizes and enhanced vacuum power available. See below.
Pump options	9 HP Honda Gas Engine (127 CFM) 13 HP Honda Gas Engine (230 CFM) 10 HP Kohler Diesel Engine (127 CFM) 13 HP Kohler Diesel Engine (230 CFM) 24 hp Honda Gas or Kohler Diesel (363 CFM) 30 HP Kohler Diesel Engine (520 CFM)
Applications	Septic pumping services, waste trap grease pumping, car wash/wash bay pump out, general wastewater pump

TVP-1000 Series

Model
TVP-1000 - DOT compliant trailer mounted
TVP-1000- DOT compliant trailer mounted with tilt tank - hydraulic tank tilting system
TVP-1000 - Stationary slide-in unit
TVP-800-200- Dual compartment 800 gallon waste, 200 gallon fresh water

Accessories/Configuration Options

Description
3" x 50 ft Non-Collapsible Suction Hose
30" Sch. 80 PVC Wand;
Rear access manway Select either 20", 25" or 36" diameter
Sight glass
Trailer mounted toolbox
Trailer mounted hose box
Rear end or side mounted pump (front mount standard)
Tank level indicator
Hydraulic tilt tank (Tilt-N-Go™)
Dual compartment waste and water

Super Duty TVP 1600 Series Vacuum Pumps



TVP-1600 Series with 1600 gallon tank.



Rear view. Optional manway shown.

TVP 1600 Series

Mounting options	DOT compliant trailer mounted or slide-in stationary unit.
Tank	Your choice of 1600 gallon single compartment waste or dual compartment waste and water.
Hoses and fittings	Qty: 1 - Select either 2"x30' or 3" x 30 ft suction non-collapsible EPDM hose (Grn/Blk) with camlocks. Includes clear swing check valve and ball valve and female camlock to connect optional accessories.
Standard Pump/Engine	9 hp Honda gas engine (127 CFM). Larger engine sizes and enhanced vacuum power available. See below.
Pump options	9 HP Honda Gas Engine (127 CFM) 13 HP Honda Gas Engine (230 CFM) 10 HP Kohler Diesel Engine (127 CFM) 13 HP Kohler Diesel Engine (230 CFM) 24 hp Honda Gas or Kohler Diesel (363 CFM) 30 HP Kohler Diesel Engine (520 CFM)
Applications	Septic pumping services, waste trap grease pumping, car wash/wash bay pump out, general wastewater pump

TVP-1600 Series

Model
TVP-1600 - DOT compliant trailer mounted
TVP-1600 - DOT compliant trailer mounted with tilt tank - hydraulic tank tilting system
TVP-1600- Stationary slide-in unit
TVP-1200-400 - Dual compartment 1200 gallon waste, 400 gallon fresh water

Accessories/Configuration Options

Description
3" x 50 ft Non-Collapsible Suction Hose
30" Sch. 80 PVC Wand;
Rear access manway Select either 20", 25" or 36" diameter
Sight glass
Trailer mounted toolbox
Trailer mounted hose box
Rear end or side mounted pump (front mount standard)
Tank level indicator
Hydraulic tilt tank (Tilt-N-Go™)
Dual compartment waste and water

Super Duty TVP 2000 Series Vacuum Pumps



TVP-2000, 2000 gallon model shown with galvanized frame, diamond plate deck and DOT compliant trailer system



Rear view. Optional manway shown

TVP 2000 Series

Mounting options	DOT compliant trailer mounted or slide-in stationary unit.
Tank	Your choice of 2000 gallon single compartment waste or dual compartment waste and water.
Hoses and fittings	Qty: 1 - Select either 2"x30' or 3" x 30 ft suction non-collapsible EPDM hose (Grn/Blk) with camlocks. Includes clear swing check valve and ball valve and female camlock to connect optional accessories.
Standard Pump/Engine	9 hp Honda gas engine (127 CFM). Larger engine sizes and enhanced vacuum power available. See below.
Pump options	9 HP Honda Gas Engine (127 CFM) 13 HP Honda Gas Engine (230 CFM) 10 HP Kohler Diesel Engine (127 CFM) 13 HP Kohler Diesel Engine (230 CFM) 24 hp Honda Gas or Kohler Diesel (363 CFM) 30 HP Kohler Diesel Engine (520 CFM)
Applications	Septic pumping services, waste trap grease pumping, car wash/wash bay pump out, general wastewater pump

TVP-2000 Series

Model
TVP-2000- DOT compliant trailer mounted
TVP-2000- DOT compliant trailer mounted with tilt tank - hydraulic tank tilting system
TVP-2000 - Stationary slide-in unit
TVP-1600 -400 Dual compartment 1600 gallon waste, 400 gallon fresh water

Accessories/Configuration Options

Description
3" x 50 ft Non-Collapsible Suction Hose
30" Sch. 80 PVC Wand;
Rear access manway Select either 20", 25" or 36" diameter
Sight glass
Trailer mounted toolbox
Trailer mounted hose box
Rear end or side mounted pump (front mount standard)
Tank level indicator
Hydraulic tilt tank (Tilt-N-Go™)
Dual compartment waste and water

Super Duty TVP 3000-5000 Series Vacuum Pumps



TVP 3000-5000 Series

Mounting options	DOT compliant trailer mounted or slide-in stationary unit.
Tank	Your choice of 3000, 4000 or 5000 gallon single compartment waste or dual compartment waste and water.
Hoses and fittings	Qty: 1 - Select either 3"x30' or 3" x 30 ft suction non-collapsible EPDM hose (Grn/Blk) with camlocks. Includes clear swing check valve and ball valve and female camlock to connect optional accessories.
Standard Pump/Engine	9 hp Honda gas engine (127 CFM). Larger engine sizes and enhanced vacuum power available. See below.
Pump options	9 HP Honda Gas Engine (127 CFM) 13 HP Honda Gas Engine (230 CFM) 10 HP Kohler Diesel Engine (127 CFM) 13 HP Kohler Diesel Engine (230 CFM) 24 hp Honda Gas or Kohler Diesel (363 CFM) 30 HP Kohler Diesel Engine (520 CFM)
Applications	Septic pumping services, waste trap grease pumping, car wash/wash bay pump out, general wastewater pump

TVP 3000-5000 Series

Model
TVP-1600 - DOT compliant trailer mounted
TVP-1600 - DOT compliant trailer mounted with tilt tank - hydraulic tank tilting system
TVP-1600- Stationary slide-in unit
TVP-1200-400 - Dual compartment 1200 gallon waste, 400 gallon fresh water

Accessories/Configuration Options

Description
3" x 50 ft Non-Collapsible Suction Hose
30" Sch. 80 PVC Wand;
Rear access manway Select either 20", 25" or 36" diameter
Sight glass
Trailer mounted toolbox
Trailer mounted hose box
Rear end or side mounted pump (front mount standard)
Tank level indicator
Hydraulic tilt tank (Tilt-N-Go™)
Dual compartment waste and water

All-In-One Vacuum and Jetter Systems

Expand your service offerings with Wastecorp's Super Duty all-in-one trailer systems with high suction vacuum pump systems, fresh water distribution capabilities, jetter function and optional auxillary compact vacuum system. With our all-in-one systems you can completely customize your systems to service catch basins, sewer lines, underground parking garages and other hard to reach areas. Contact a Wastecorp Pump systems expert at 1-888-829-2783 to get started today.



Automated and manual industrial grade hose reels available.



Customize with productivity enhancing ramps and access hatches.



Powerful Jetter Systems to service catch basins, clean sewer lines and more.

SLIDE -IN VACUUM PUMPS. SKID MOUNTED SO YOU CAN MOUNT ALMOST ANYWHERE.

Slide-in vacuum pump systems from Wastecorp offer a variety of tank sizes and configurations designed to pump septic waste, grease trap waste, wastewater containing grit and more . Whether you are mounting on a truck, concrete pad or moving it frequently with a forklift, you'll get the high quality construction coupled with powerful Super Duty vacuum pump technology. Super Duty Slide-in units are available for every Super Duty model we manufacture.



Rear mounted pump with dual fork hose stand



Slide-in vacuum pump with front mounted pump and engine.



Marine vacuum pump system with integrated control panel and hose stand.



Front mounted pump and control panel May be suitable for confined spaces.

With a variety of configuration options, Wastecorp's skid mounted honey wagons can be mounted almost anywhere such as golf carts, pump out boats and more.

WASTECORP SLIDE-IN VACUUM PUMPS. POWERFUL. VERSATILE. DEPENDABLE.



Custom Build Your System



Various Manway Sizes Available

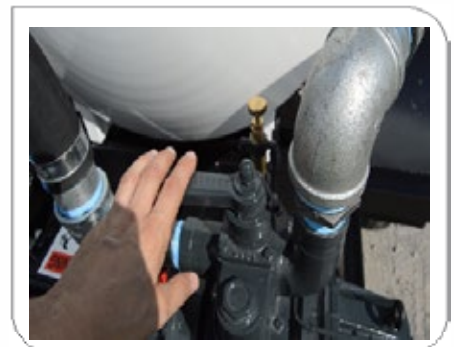

Gas, Diesel or Electric Pump Systems

Super Duty Vacuum Pump Sample Installations



Super Duty TVP-600 Series vacuum pump, trailer mounted with Tilt-N-Go, tilt tank feature. Operator controls tilt function with remote control. wireless functions also available. Used to pump out portable toilets on construction sites.



Super Duty TVP-450 Series, 450 gallon slide-in vacuum pump system. Shown Mounted in the bed of a Ford F-150 truck with 6' box. Customer slide in vacuum pumps available for all truck bed sizes and configurations. Waste tank only and dual compartment waste and water available.



Super Duty TVP-150 Series, 150 gallon vacuum pump systems mounted in the rear bed of John Deere Gator utility vehicles. Top mounted vacuum pump to conserve space, alternate pump mountings available. Designed for high suction power around government operated sports/entertainment complex. Ideal for facilities maintenance, septic, waste oil and grease.



Super Duty TVP 450-200, dual compartment mounted vacuum pump. 450 gallon waste, 200 gallon fresh water compartment. Used on a construction site to pump out portable toilets and refill with fresh water. Also includes a high pressure water pump to rinse down area.

VACUUM PUMPS DESIGNED FOR YOUR UNIQUE APPLICATION.

From pumping out waste pits, lagoons, septic waste, municipal sewers to restaurant waste trap grease, used oil and septic waste, Super Duty high suction vacuum pumps can help you get the job done quickly and likely at a fraction of the cost of typical vacuum pump services.

Wastecorp offers slide-in, skid mounted vacuum pumps and DOT compliant trailer mounted vacuum pumps. Vacuum power is available from 92-520 CFM with your choice of single compartment or dual compartment tanks. Select from waste only tanks or waste and fresh water compartments. Super Duty vacuum trailer and slide-in vacuum pumps are an ideal alternative to vacuum trucks for pumping out portable toilets, porta potties, grit, oil and more.



North America: 1-888-829-2783

Fax: 1-888-883-3320

Worldwide: +1-201-445-2882

Fax: +1-201-445-3252

E-mail: info@wastecorp.com

Internet: www.wastecorp.com



Wastecorp Pumps is an ISO 9001 and 14001 certified pump manufacturer.

Specifications, literature and illustrative material are accurate at the time of publication but are subject to change without notice. Illustrations may include optional equipment and accessories and may not include all standard equipment. Super Duty, Wastecorp and globes are trademarks of Wastecorp Pumps Inc .

© 2025 WPI. V1 02/22. Exclusive License to Wastecorp Pumps,LLC. All rights reserved. New York, NY 10024