



Super Duty®

TVP-40™ Series Vacuum Pumps

FEATURES

Designed for septic, waste trap grease, marine, liquid food, chemical containment, sump cleaning

Pumps suspended solids

Dry start suction lift to 25 ft.

Safe to run dry

Low emulsion

Low sheering action

Pumps available to 60 GPM

Automatic continuous duty

Wastecorp is An ISO 9001 and ISO 14001 pump manufacturer



Optional configuration with accessories shown. Dual axle ATV vacuum pump trailer with Honda electric start engine)

Pump Specifications	TVP 40
Pump	37 CFM (92-520 available)
Tank	Steel, 40 or 50 gallons (Customer to specify)
Connections	1½ x 2" NPT Intake & Discharge w/ motorized ball valve
Finish	White. Optional colors available upon request
Hoses	30 ft Intake Hose Assembly
Accessories	Potty wand
Performance Specifications*	
Max. suction lift	25 ft
Max. suction distance	1200 ft
Max. suction performance	60 GPM
Max. discharge head	30 ft
Max. discharge distance	1500 ft

Base Model Approximate Dimensions (Single Axle - Dolly Style)

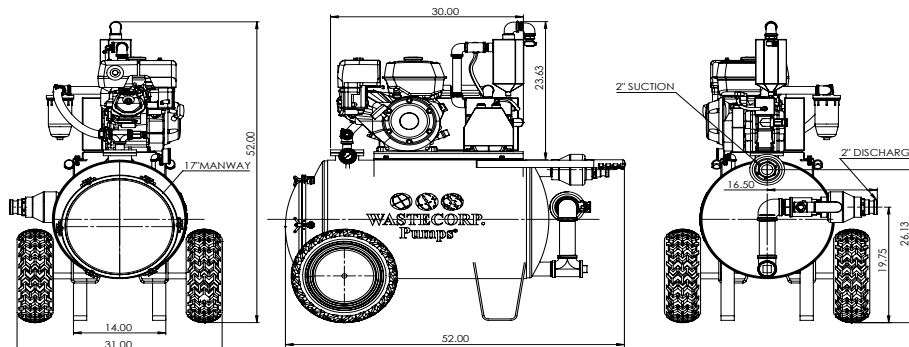

* Specifications shown with highest 520 CFM rated optional pump. Standard 37 CFM included. Specifications and dimensions subject to change without notice.

© Wastecorp 2019. No reproduction without permission.